

# **WX/ASR Basic Operation and Baseline Configuration**

## **Annex A: IRIS Configuration**

---

**Prepared by:**       **SIGMET, Inc.**  
                          **2 Park Drive, Unit 1**  
                          **Westford, MA 01886**  
                          **TEL (978) 692-9234**  
                          **FAX (978) 692-9575**  
                          **support@sigmet.com**

**Revision Dates:**   **Rev 1: 21 March 2005**

## 1. Document Scope

This document describes the configuration of the IRIS software for the systems provided by SIGMET, Inc. for the WX/ASR project. The figure on the next page shows a block diagram of the system. The IRIS setup and menu settings are documented here for the two radar systems (nodes “rcp-a” and “rcp-b”) and the analysis system (node “analysis”). The organization of this Annex is shown below:

## 2. Radar System Configuration

2.0-A Setup Menu Listings for rcp-a

2.0-B Setup Menu Listings for rcp-b

*(Note: the Radar A and B IRIS Menus are identical in all respects.)*

2.1 DEFAULT Mode

2.1.1 Radar Status Menu

2.1.2 DEFAULT Product Schedule Menu

2.1.3 DEFAULT Product Configuration Menu

2.1.4 DEFAULT Product Output Menu

2.2 ASR Mode

2.2.1 Radar Status Menu

2.2.2 ASR TASK Configuration and Scheduling

2.3 WX Mode

2.3.1 Radar Status Menu

2.3.2 WX TASK Configuration and Scheduling

## 3. Analysis System Configuration

3.0 Setup Menu Listing

3.1 DEFAULT Radar Status Menu

3.2 DEFAULT Product Output

3.3 ASR Mode Products and Product Schedule

3.3.1 ASR Mode Product Schedule

3.3.2 ASR Mode Product Configurations

3.4 WX Mode Products

3.4.1 ASR Mode Product Schedule

3.4.2 ASR Mode Product Configuration

# Figure 1: WX/ASR Network Layout

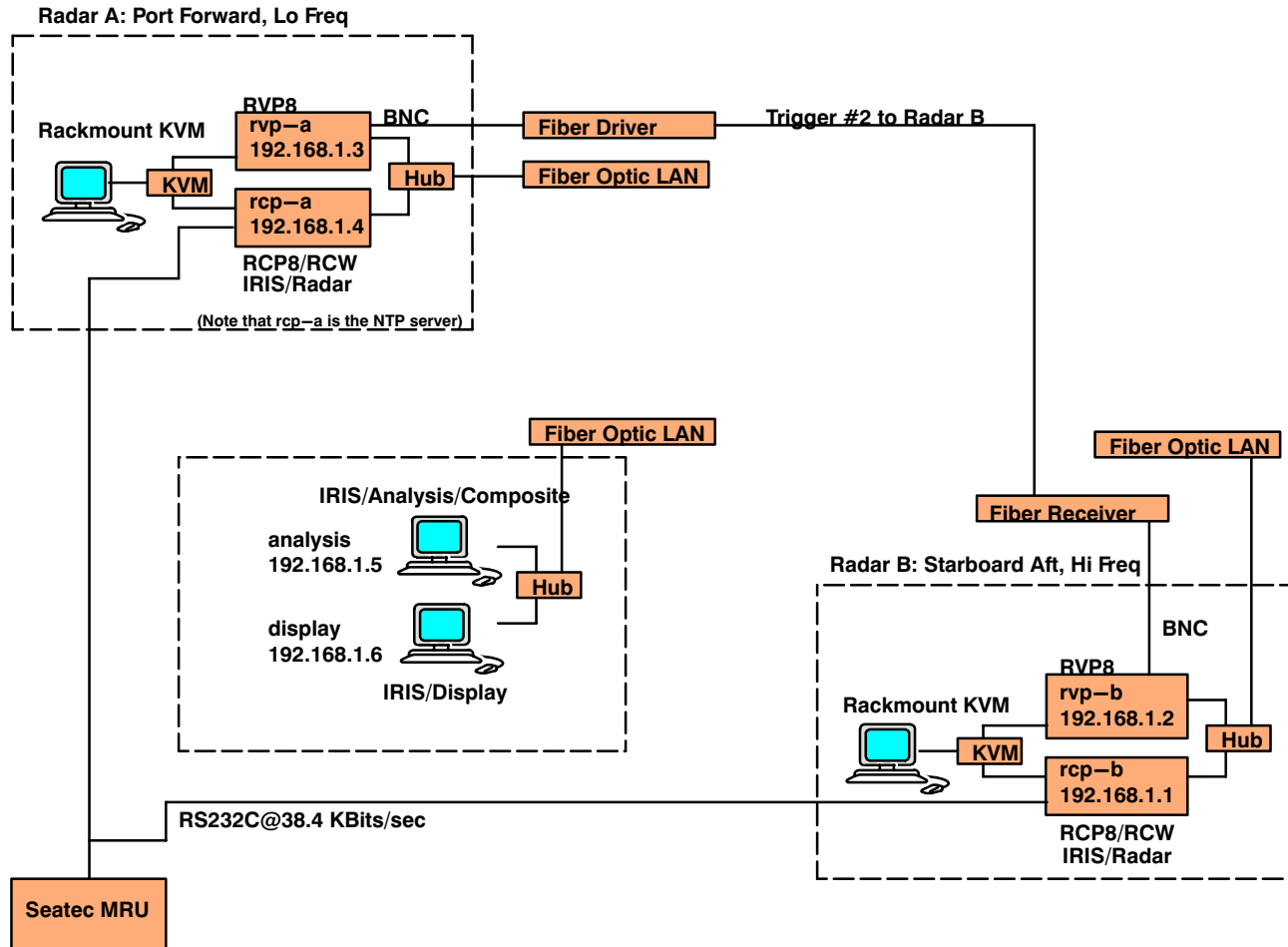

## 2. Radar System Configuration

### 2.0-A Setup Menu Listings for Radar A

```
=====
Radar Video Processor Setups, rcp-a
=====

System Type
  System has a signal processor      : Yes
  Interface to RVP                   : DspExport
  DspExport hostname/IP-Address     : rvp8-test.sigmet.com
  DspExport Port Number              : 30740

Real Time Display
  System transmits RTD               : Yes
  RTD transmitter priority           : -4
  Max. number of bins in display    : 500
  Reflectivity data                  : Included
  Velocity data                      : Included
  Width data                         : Excluded
  Name of RTD transmitter #1        : rtd_v1_xmt
  Broadcast IP address #1           : 192.168.1.255
  UDP port #1                       : 30730
  Name of RTD transmitter #2        :
  Name of RTD transmitter #3        :
  Name of RTD transmitter #4        :
  Name of RTD transmitter #5        :
  Name of RTD transmitter #6        :

=====
Radar Control Processor Setups, rcp-a
=====

Interface to RCP
  System has an antenna              : Yes
  Main Interface to RCP              : Network
  Antenna angle insertion source     : Native RCP8
  Is this the 1 controlling host     : Yes
  Network Multicast Address          : 239.255.0.2
  Network Port Number                : 30785
  Network Interface                  : eth0
  Average network delay              : 1 ms
  Receive format from RCP            : RCV03 (Shipboard)
  Transmit format to RCP             : XMT02 (Enhanced)

Advanced Interface Features
  Auxiliary receive format           : No Reception
  Start RCP Simulator                : No
  Transmit subprocess priority       : -15
  Receive subprocess priority        : -15
  Timezone of time packets           : UTC
  Trust timestamps in RCVxx          : Yes
  Packet Logging                     : None

Radar Site and Antenna Placement
  Ground height above sea level      : 0.0 meters
```



```
Siggen Fault Status           : Disabled
RCP Shutdown Status          : Enabled
                               : Fault: HIGH
                               : Type: Normal
Low Airflow Status           : Disabled
Low Waveguide Pressure Status : Enabled
                               : Fault: HIGH
                               : Type: Normal
Antenna Local Mode Status    : Enabled
                               : Local: HIGH
T/R Local Mode Status        : Enabled
                               : Local: HIGH
Safety Interlock Status      : Disabled
Standby Status               : Enabled
                               : Standby: HIGH
Magnetron Current Status     : Disabled
Azimuth Encoder Status       : Disabled
Elevation Encoder Status     : Disabled
Network Status Reports to the RCP
  Reporting                   : Disabled
RST Mode to Number Mapping
  Radar Status name for MODE #1 : WX
  Radar Status name for MODE #2 :
  Radar Status name for MODE #3 :
  Radar Status name for MODE #4 :
  Radar Status name for MODE #5 : ASR
  Radar Status name for MODE #6 :
  Radar Status name for MODE #7 :
  Mode to use when RCP is dead  : 1
  Mode reporting delay          : 1.0 sec
=====
IRIS Input Device Setups, rcp-a
=====
Input Device Specifications
  Number of input devices : 0
=====
IRIS INGEST Setups, rcp-a
=====
Data Source Selection
  INGEST data source           : From DSP
  Reset the DSP on INGEST startup : Yes
Signal Processing and Data Storage
  Data truncation height       : 20.000 km
  Type of angle syncing        : Dynamic
  Manner of angle acquisition   : Binary TAGs
  DSP parameter computations    : R2 algorithms
  Extended header format       : V1 (V0 + Nav)
Scanning Options
  Reset the RCP on INGEST startup : No
  Task Scheduling Control       : Active Only
  RHI elevation speedup ratio   : 10.00
```

Permissible AZ error during scans : 0.50 degrees  
Permissible EL error during scans : 0.50 degrees  
AZ maximum speed at end positions : 0.50 deg/sec  
EL maximum speed at end positions : 0.50 deg/sec  
AZ speed tolerance : 1.00 deg/sec  
AZ minimum expected moving speed : 0.20 deg/sec  
EL minimum expected moving speed : 0.20 deg/sec  
AZ settling time between sweeps : 1.00 seconds  
EL settling time between sweeps : 1.00 seconds  
Direction of continuous scans : Clockwise  
Coasting time between tasks : 60 seconds max

DSP Noise Sampling

Perform noise sampling : Never

Transmitter Control

Idle time to shut off transmitter : 300 seconds  
Warmup time for transmitter : 10 seconds  
Pulsewidth and PRF are set : at task start

Zc: Clutter Suppression via Clutter Map

Excess power needed for valid dBZ : 10.0 dB  
Elevation tolerance for matchup : 1.00 degrees  
Non-zero velocity criterion : Check Velocity  
Clutter correction in ReINGEST : Disabled

Zc: Intervening Attenuation Correction

Z attenuation constant : 0.000112 dB/km  
Z attenuation exponent : 0.62  
Maximum Z for correction : 50.0 dBZ  
Maximum cumulative correction : 6.0 dB  
Atten correction in ReINGEST : Disabled

Zc: Target Detection Correction

Target detection in ReINGEST : Disabled

Vc: VVP Unfolding of Velocity

Maximum age of the "UNFOLD" VVP : 30.0 minutes  
Maximum separation to the VVP : 50.0 km  
Velocity unfolding in ReINGEST : Disabled

Vc: Velocity Fallspeed Correction

Vt-Z Constant above melting level : 0.80 m/s  
Vt-Z Exponent above melting level : 0.060  
Vt-Z Constant below melting level : 2.70 m/s  
Vt-Z Exponent below melting level : 0.110  
Fallspeed correction in ReINGEST : Disabled

Melting Levels

Melting Levels : Disabled

=====  
IRIS General Setups, rcp-a  
=====

Modes and Protocols

Timezone for data recording : UTC  
Operating system's time : Set from RCP  
Memory-mapped I/O : Available in OS  
External RCP mode change : Disabled

External socket mode change : Disabled  
Status product mode change : Enabled  
Supplied by (Site Code) : SBX  
Response to fatal errors : Restart Processes  
Maximum number of IRIS clients : 10 clients

Speech and Signaling  
Signal network warnings < : 600 seconds old  
Speak/Beep text products : No  
Speak/Beep mode changes : No  
Speak/Beep fatal errors : No  
Speak/Beep BITE faults : No

File System Quotas  
Total space for INGEST files : 1000.0 megabytes  
Kept INGEST file space : 50% of total  
Total space for RAW products : 1000.0 megabytes  
Kept RAW-Product file space : 50% of total  
Total space for Other-Products : 1000.0 megabytes  
Kept Other-Product file space : 50% of total  
Maximum Products on Disk : 10000  
Maximum Products on Archive : 64000  
Number of LOG files to retain : 5

Run-Time Priorities  
INGEST process priority : -8  
INGFIO process priority : -8  
INPUT process priority : 0  
PRODUCT process priority : 8  
REINGEST process priority : 8  
NETWORK process priority : 4  
OUTPUT process priority : 4  
ARCHIVE process priority : 4  
SERVER process priority : 0  
WATCHDOG process priority : 0

Window Alert Configuration  
Multi-site fault rule : FAULT on one  
Alert Style : Disabled

List Of Radar Site Names and Site Codes  
Site #0 (Unknown) code : XXX  
Check for Fault : No  
Site #1 name : SBX, DISPLAY  
Code : SBC  
Check for Fault : No  
Site #2 name : SBX, ANALYSIS  
Code : SBX  
Check for Fault : No  
Site #3 name : SBX, RADARA  
Code : SBA  
Check for Fault : No  
Site #4 name : SBX, RADARB  
Code : SBB  
Check for Fault : No  
Site #5 name :  
Site #6 name :

Site #7 name :  
Site #8 name :  
Site #9 name :  
Site #10 name :  
Site #11 name :  
Site #12 name :  
Site #13 name :  
Site #14 name :  
Site #15 name :  
Site #16 name :  
Site #17 name :  
Site #18 name :  
Site #19 name :  
Site #20 name :  
Site #21 name :  
Site #22 name :  
Site #23 name :  
Site #24 name :  
Site #25 name :  
Site #26 name :  
Site #27 name :  
Site #28 name :  
Site #29 name :  
Site #30 name :

=====  
IRIS PRODUCT Setups, rcp-a  
=====

Product Generation

Products from partial INGEST scans : No  
Default Z/R relationship constant : 200.00  
Default Z/R relationship exponent : 1.60  
Product arrival wait time : 1.0 minutes  
Raingage data arrival wait time : 1.0 minutes  
Signal if busy more than : 0.0 minutes  
Alternating polarization features : Enabled  
Default K/R relationship constant : 0.030  
Default K/R relationship exponent : 1.15  
Read cache size : 0.0 megabytes  
Zero reference height : 0 meters

Reflectivity Profile and Wind

Use Gradient in CAPPI & XSECT : Yes  
Gradient Above Melting : 10.0 dB/km  
Gradient Below Melting : 1.0 dB/km  
Melting Layer Thickness : 1.00 km  
Melting Layer Intensity : 7.0 dB  
Default Wind : Disabled

Status Products

STATUS product generation : Enabled  
Time between status products : 1.0 minutes  
Make product for each task : No  
STATUS Prod maximum file count : 25 files

```
STATUS product receive timeout      : Enabled
Timeout after                       : 2.0 minutes

Product Transmission and Display
WARN max time difference             : 15.0 minutes
TRACK max time difference            : 0.50 hours
FCAST max time difference            : 15.0 minutes
Default max time difference         : 15.0 minutes
Maximum files queued for send       : 3 files
Centroid value signal               : Average
Label bottom of SLINE display       : Enabled
Label bottom of TDWR display        : Enabled
Label bottom of TRACK display       : Enabled
Label bottom of WARN display        : Enabled

Product Scheduling
BEAM Product Priority               : 20
CAPPI Product Priority              : 20
CATCH Product Priority              : 20
COMP Product Priority               : 20
DWELL Product Priority              : 20
FCAST Product Priority              : 20
HMAX Product Priority               : 20
MAX Product Priority                : 20
NDOP Product Priority               : 20
PPI Product Priority                : 20
RAIN1 Product Priority              : 20
RAINN Product Priority              : 20
RAW Product Priority                : 20
RHI Product Priority                : 20
RTI Product Priority                : 20
SHEAR Product Priority              : 20
SLINE Product Priority              : 20
SRI Product Priority                : 20
TOPS Product Priority               : 20
TRACK Product Priority              : 20
VIL Product Priority                : 20
VVP Product Priority                : 20
WARN Product Priority               : 40
WIND Product Priority               : 20
XSECT Product Priority              : 30

Warning Region #1
Name                               :
Warning Region #2
Name                               :
Warning Region #3
Name                               :
Warning Region #4
Name                               :
Warning Region #5
Name                               :
Warning Region #6
Name                               :
```

Warning Region #7  
Name :

Warning Region #8  
Name :

Warning Region #9  
Name :

Warning Region #10  
Name :

Warning Region #11  
Name :

Warning Region #12  
Name :

Warning Region #13  
Name :

Warning Region #14  
Name :

Warning Region #15  
Name :

Warning Region #16  
Name :

Warning Region #17  
Name :

Warning Region #18  
Name :

Warning Region #19  
Name :

Warning Region #20  
Name :

Warning Region #21  
Name :

Warning Region #22  
Name :

Warning Region #23  
Name :

Warning Region #24  
Name :

Warning Region #25  
Name :

Warning Region #26  
Name :

Warning Region #27  
Name :

Warning Region #28  
Name :

Warning Region #29  
Name :

Warning Region #30  
Name :

Warning Region #31  
Name :

Warning Region #32  
Name :

=====  
License and Site Setups, rcp-a  
=====

License and Site Information  
00000001-060101-WXRK4E-01-4JMNRYR  
00000001-060101-WXRK4E-03-MC3TAA  
00000004-060101-WXRK4E-05-9X739J

Radar  
SBX, RADARA  
SBX, RADARA  
\*\*\*\*\*

=====  
IRIS Output Device Setups, rcp-a  
=====

Output Device Specifications

Number of output devices : 2

Output Device #1  
Device type : Window  
Unit number : 1  
Menu alias : RADAR 1 Window  
Min time between output : 0 sec  
Device movie length : 50 frames  
Initial width of image : 720 pixels  
Initial height of image : 720 pixels  
Initial horizontal offset : 10 pixels  
Initial vertical offset : 10 pixels  
Slide Show : Disable on startup  
Display Name : :0.0

Output Device #2  
Device type : Network  
Unit number : 1  
Menu alias : Net To Analysis  
Min time between output : 0 sec  
File format : IRIS (Def)  
Filename format : Default  
Compression scheme : None  
Notification scheme : TCPIP  
Target directory : /usr/iris\_data/product/  
Copy scheme : RCP  
User name : operator

Notification port number : 30725  
Recipient host name : analysis

=====  
IRIS Web Setups, rcp-b  
=====

IRIS Web Specifications  
Max Simultaneous Clients : 10  
Number of Web Users : 0  
Require Login : Yes

## 2.0-B Setup Menu Listings for Radar B

=====  
Radar Video Processor Setups, rcp-b  
=====

### System Type

System has a signal processor : Yes  
Interface to RVP : DspExport  
DspExport hostname/IP-Address : rvp-b  
DspExport Port Number : 30740

### Real Time Display

System transmits RTD : Yes  
RTD transmitter priority : -4  
Max. number of bins in display : 500  
Reflectivity data : Included  
Velocity data : Included  
Width data : Excluded  
Name of RTD transmitter #1 : rtd\_v1\_xmt  
Broadcast IP address #1 : 192.168.1.255  
UDP port #1 : 30730  
Name of RTD transmitter #2 :  
Name of RTD transmitter #3 :  
Name of RTD transmitter #4 :  
Name of RTD transmitter #5 :  
Name of RTD transmitter #6 :

=====  
Radar Control Processor Setups, rcp-b  
=====

### Interface to RCP

System has an antenna : Yes  
Main Interface to RCP : Network  
Antenna angle insertion source : Normal RCP  
Is this the 1 controlling host : Yes  
Network Multicast Address : 239.255.0.1  
Network Port Number : 30785  
Network Interface : eth0  
Average network delay : 1 ms  
Receive format from RCP : RCV03 (Shipboard)  
Transmit format to RCP : XMT02 (Enhanced)

### Advanced Interface Features

Auxiliary receive format : No Reception  
Start RCP Simulator : No  
Transmit subprocess priority : -15  
Receive subprocess priority : -15  
Timezone of time packets : UTC  
Trust timestamps in RCVxx : Yes  
Packet Logging : None

### Radar Site and Antenna Placement

Ground height above sea level : 0.0 meters  
Antenna height above the ground : 50.0 meters



```
Low Airflow Status           : Disabled
Low Waveguide Pressure Status : Disabled
Antenna Local Mode Status    : Enabled
                              : Local: HIGH
T/R Local Mode Status        : Enabled
                              : Local: HIGH
Safety Interlock Status      : Disabled
Standby Status               : Enabled
                              : Standby: HIGH
Magnetron Current Status     : Enabled
                              : Fault: HIGH
                              : Type: Normal
Azimuth Encoder Status       : Disabled
Elevation Encoder Status     : Disabled

Network Status Reports to the RCP
Reporting                     : Disabled

RST Mode to Number Mapping
Radar Status name for MODE #1 : WX
Radar Status name for MODE #2 :
Radar Status name for MODE #3 :
Radar Status name for MODE #4 :
Radar Status name for MODE #5 : ASR
Radar Status name for MODE #6 :
Radar Status name for MODE #7 :
Mode to use when RCP is dead  : 1
Mode reporting delay          : 1.0 sec

=====
IRIS Input Device Setups, rcp-b
=====

Input Device Specifications
Number of input devices : 0

=====
IRIS INGEST Setups, rcp-b
=====

Data Source Selection
INGEST data source           : From DSP
Reset the DSP on INGEST startup : Yes

Signal Processing and Data Storage
Data truncation height      : 20.000 km
Type of angle syncing       : Dynamic
Manner of angle acquisition  : Binary TAGs
DSP parameter computations   : R2 algorithms
Extended header format      : V1 (V0 + Nav)

Scanning Options
Reset the RCP on INGEST startup : No
Task Scheduling Control       : Active Only
RHI elevation speedup ratio   : 10.00
Permissible AZ error during scans : 0.50 degrees
Permissible EL error during scans : 0.50 degrees
```

AZ maximum speed at end positions : 0.50 deg/sec  
EL maximum speed at end positions : 0.50 deg/sec  
AZ speed tolerance : 1.00 deg/sec  
AZ minimum expected moving speed : 0.20 deg/sec  
EL minimum expected moving speed : 0.20 deg/sec  
AZ settling time between sweeps : 1.00 seconds  
EL settling time between sweeps : 1.00 seconds  
Direction of continuous scans : Clockwise  
Coasting time between tasks : 60 seconds max

DSP Noise Sampling  
Perform noise sampling : Never

Transmitter Control  
Idle time to shut off transmitter : 300 seconds  
Warmup time for transmitter : 10 seconds  
Pulsewidth and PRF are set : at task start

Zc: Clutter Suppression via Clutter Map  
Excess power needed for valid dBZ : 10.0 dB  
Elevation tolerance for matchup : 1.00 degrees  
Non-zero velocity criterion : Check Velocity  
Clutter correction in ReINGEST : Disabled

Zc: Intervening Attenuation Correction  
Z attenuation constant : 0.000112 dB/km  
Z attenuation exponent : 0.62  
Maximum Z for correction : 50.0 dBZ  
Maximum cumulative correction : 6.0 dB  
Atten correction in ReINGEST : Disabled

Zc: Target Detection Correction  
Target detection in ReINGEST : Disabled

Vc: VVP Unfolding of Velocity  
Maximum age of the "UNFOLD" VVP : 30.0 minutes  
Maximum separation to the VVP : 50.0 km  
Velocity unfolding in ReINGEST : Disabled

Vc: Velocity Fallspeed Correction  
Vt-Z Constant above melting level : 0.80 m/s  
Vt-Z Exponent above melting level : 0.060  
Vt-Z Constant below melting level : 2.70 m/s  
Vt-Z Exponent below melting level : 0.110  
Fallspeed correction in ReINGEST : Disabled

Melting Levels  
Melting Levels : Disabled

=====  
IRIS General Setups, rcp-b  
=====

Modes and Protocols  
Timezone for data recording : UTC  
Operating system's time : Unaffected by IRIS  
Memory-mapped I/O : Available in OS  
External RCP mode change : Disabled

External socket mode change : Enabled  
Status product mode change : Enabled  
Supplied by (Site Code) :  
Response to fatal errors : Restart Processes  
Maximum number of IRIS clients : 10 clients

Speech and Signaling

Signal network warnings < : 600 seconds old  
Speak/Beep text products : No  
Speak/Beep mode changes : No  
Speak/Beep fatal errors : No  
Speak/Beep BITE faults : No

File System Quotas

Total space for INGEST files : 1000.0 megabytes  
Kept INGEST file space : 50% of total  
Total space for RAW products : 1000.0 megabytes  
Kept RAW-Product file space : 50% of total  
Total space for Other-Products : 1000.0 megabytes  
Kept Other-Product file space : 50% of total  
Maximum Products on Disk : 10000  
Maximum Products on Archive : 64000  
Number of LOG files to retain : 5

Run-Time Priorities

INGEST process priority : -8  
INGFIO process priority : -8  
INPUT process priority : 0  
PRODUCT process priority : 8  
REINGEST process priority : 8  
NETWORK process priority : 4  
OUTPUT process priority : 4  
ARCHIVE process priority : 4  
SERVER process priority : 0  
WATCHDOG process priority : 0

Window Alert Configuration

Multi-site fault rule : FAULT on one  
Alert Style : Disabled

List Of Radar Site Names and Site Codes

Site #0 (Unknown) code : XXX  
Check for Fault : No  
Site #1 name : SBX, DISPLAY  
Code : SBC  
Check for Fault : No  
Site #2 name : SBX, ANALYSIS  
Code : SBX  
Check for Fault : No  
Site #3 name : SBX, RADARA  
Code : SBA  
Check for Fault : No  
Site #4 name : SBX, RADARB  
Code : SBB  
Check for Fault : No  
Site #5 name :

Site #6 name :  
Site #7 name :  
Site #8 name :  
Site #9 name :  
Site #10 name :  
Site #11 name :  
Site #12 name :  
Site #13 name :  
Site #14 name :  
Site #15 name :  
Site #16 name :  
Site #17 name :  
Site #18 name :  
Site #19 name :  
Site #20 name :  
Site #21 name :  
Site #22 name :  
Site #23 name :  
Site #24 name :  
Site #25 name :  
Site #26 name :  
Site #27 name :  
Site #28 name :  
Site #29 name :  
Site #30 name :

=====  
IRIS PRODUCT Setups, rcp-b  
=====

Product Generation

Products from partial INGEST scans : No  
Default Z/R relationship constant : 200.00  
Default Z/R relationship exponent : 1.60  
Product arrival wait time : 1.0 minutes  
Raingage data arrival wait time : 1.0 minutes  
Signal if busy more than : 0.0 minutes  
Alternating polarization features : Enabled  
Default K/R relationship constant : 0.030  
Default K/R relationship exponent : 1.15  
Read cache size : 0.0 megabytes  
Zero reference height : 0 meters

Reflectivity Profile and Wind

Use Gradient in CAPPI & XSECT : Yes  
Gradient Above Melting : 10.0 dB/km  
Gradient Below Melting : 1.0 dB/km  
Melting Layer Thickness : 1.00 km  
Melting Layer Intensity : 7.0 dB  
Default Wind : Disabled

Status Products

STATUS product generation : Enabled  
Time between status products : 1.0 minutes  
Make product for each task : No

STATUS Prod maximum file count : 25 files  
STATUS product receive timeout : Enabled  
Timeout after : 2.0 minutes

Product Transmission and Display

WARN max time difference : 15.0 minutes  
TRACK max time difference : 0.50 hours  
FCAST max time difference : 15.0 minutes  
Default max time difference : 15.0 minutes  
Maximum files queued for send : 3 files  
Centroid value signal : Average  
Label bottom of SLINE display : Enabled  
Label bottom of TDWR display : Enabled  
Label bottom of TRACK display : Enabled  
Label bottom of WARN display : Enabled

Product Scheduling

BEAM Product Priority : 20  
CAPPI Product Priority : 20  
CATCH Product Priority : 20  
COMP Product Priority : 20  
DWELL Product Priority : 20  
FCAST Product Priority : 20  
HMAX Product Priority : 20  
MAX Product Priority : 20  
NDOP Product Priority : 20  
PPI Product Priority : 20  
RAIN1 Product Priority : 20  
RAINN Product Priority : 20  
RAW Product Priority : 20  
RHI Product Priority : 20  
RTI Product Priority : 20  
SHEAR Product Priority : 20  
SLINE Product Priority : 20  
SRI Product Priority : 20  
TOPS Product Priority : 20  
TRACK Product Priority : 20  
VIL Product Priority : 20  
VVP Product Priority : 20  
WARN Product Priority : 40  
WIND Product Priority : 20  
XSECT Product Priority : 30

Warning Region #1  
Name :

Warning Region #2  
Name :

Warning Region #3  
Name :

Warning Region #4  
Name :

Warning Region #5  
Name :

---

Warning Region #6  
Name :

Warning Region #7  
Name :

Warning Region #8  
Name :

Warning Region #9  
Name :

Warning Region #10  
Name :

Warning Region #11  
Name :

Warning Region #12  
Name :

Warning Region #13  
Name :

Warning Region #14  
Name :

Warning Region #15  
Name :

Warning Region #16  
Name :

Warning Region #17  
Name :

Warning Region #18  
Name :

Warning Region #19  
Name :

Warning Region #20  
Name :

Warning Region #21  
Name :

Warning Region #22  
Name :

Warning Region #23  
Name :

Warning Region #24  
Name :

Warning Region #25  
Name :

Warning Region #26  
Name :

Warning Region #27  
Name :

Warning Region #28  
Name :

Warning Region #29  
Name :

Warning Region #30  
Name :

Warning Region #31  
Name :

Warning Region #32  
Name :

=====  
License and Site Setups, rcp-b  
=====

License and Site Information  
00000001-041001-XEHFRC-01-XEJEEW  
00000001-041001-XEHFRC-03-H7XEJ7

Radar  
SBX, RADARB  
SBX, RADARB  
\*\*\*\*\*

=====  
IRIS Output Device Setups, rcp-b  
=====

Output Device Specifications

Number of output devices : 3

Output Device #1

Device type : Window  
Unit number : 1  
Menu alias : RADAR 1 Window  
Min time between output : 0 sec  
Device movie length : 50 frames  
Initial width of image : 720 pixels  
Initial height of image : 720 pixels  
Initial horizontal offset : 10 pixels  
Initial vertical offset : 10 pixels  
Slide Show : Disable on startup  
Display Name : :0.0

Output Device #2

Device type : Network  
Unit number : 1  
Menu alias : Net To Analysis  
Min time between output : 0 sec  
File format : IRIS (Def)  
Filename format : Default  
Compression scheme : None  
Notification scheme : TCPIP

Target directory : /usr/iris\_data/product/  
Copy scheme : RCP  
User name : operator  
Notification port number : 30725  
Recipient host name : analysis

Output Device #3

Device type : Network  
Unit number : 2  
Menu alias : Net to RADARA  
Min time between output : 0 sec  
File format : IRIS (Def)  
Filename format : Default  
Compression scheme : None  
Notification scheme : TCPIP  
Target directory : /usr/iris\_data/product/  
Copy scheme : RCP  
User name : operator  
Notification port number : 30725  
Recipient host name : rcp-a

=====  
IRIS Web Setups, rcp-b  
=====

IRIS Web Specifications

Max Simultaneous Clients : 10  
Number of Web Users : 0  
Require Login : Yes

## 2.1 Radar System DEFAULT Mode

**Note: The Radar A and Radar B IRIS Menus are identical in all respects.**

This mode is the default power up mode. It also serves as a standby mode for maintenance. Features of this mode are:

- Radar Status Menu- has both the Radar Process (stops antenna) and Radiate set to off. This provides a safe power-up environment for personnel.
- DEFAULT TASK Schedule- is empty. No scan TASK's are required.
- DEFAULT Product Schedule- is used for all modes (WX and ASR). This minimizes the system configuration management.
- DEFAULT Product Configurations- are used for all modes (Wx and ASR). The only products produced are RAW products.
- DEFAULT Output Schedule- is used for all modes (WX and ASR). This minimizes the system configuration management.

### 2.1.1 Radar Status Menu

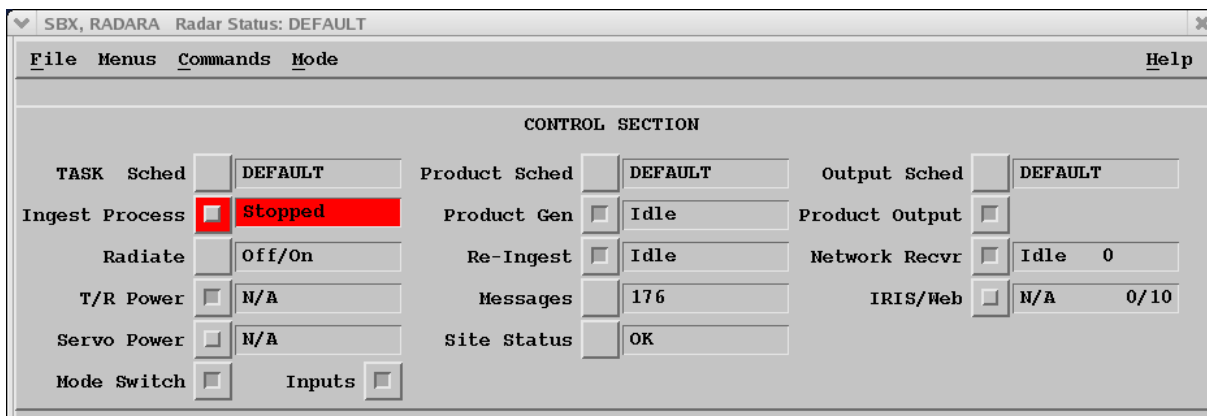

### 2.1.2 DEFAULT Product Schedule Menu

Used for all modes (DEFAULT, WX, ASR)

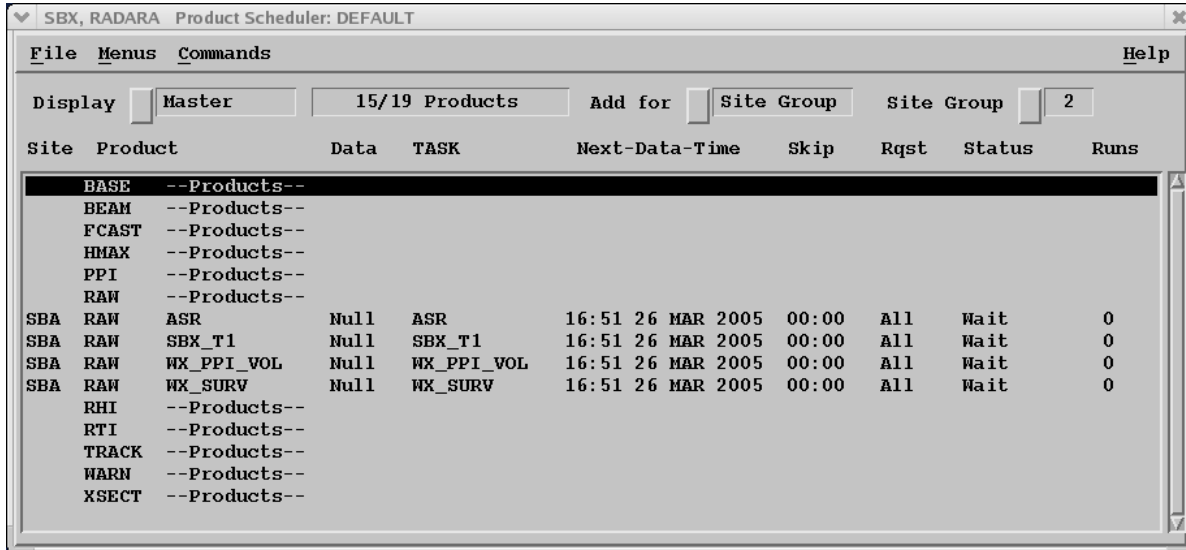

The screenshot shows a window titled "SBX, RADARA Product Scheduler: DEFAULT". It has a menu bar with "File", "Menus", "Commands", and "Help". Below the menu bar, there are several controls: "Display" with a dropdown set to "Master", "15/19 Products", "Add for" with a dropdown set to "Site Group", and "Site Group" with a dropdown set to "2". The main area is a table with the following columns: "Site", "Product", "Data", "TASK", "Next-Data-Time", "Skip", "Rqst", "Status", and "Runs".

Site	Product	Data	TASK	Next-Data-Time	Skip	Rqst	Status	Runs
	BASE	--Products--						
	BEAM	--Products--						
	FCAST	--Products--						
	HMAX	--Products--						
	PPI	--Products--						
	RAW	--Products--						
SBA	RAW	ASR	Null ASR	16:51 26 MAR 2005	00:00	All	Wait	0
SBA	RAW	SBX_T1	Null SBX_T1	16:51 26 MAR 2005	00:00	All	Wait	0
SBA	RAW	WX_PPI_VOL	Null WX_PPI_VOL	16:51 26 MAR 2005	00:00	All	Wait	0
SBA	RAW	WX_SURV	Null WX_SURV	16:51 26 MAR 2005	00:00	All	Wait	0
	RHI	--Products--						
	RTI	--Products--						
	TRACK	--Products--						
	WARN	--Products--						
	XSECT	--Products--						

### 2.1.3 DEFAULT Product Configuration Menus

RAW Product for ASR TASK

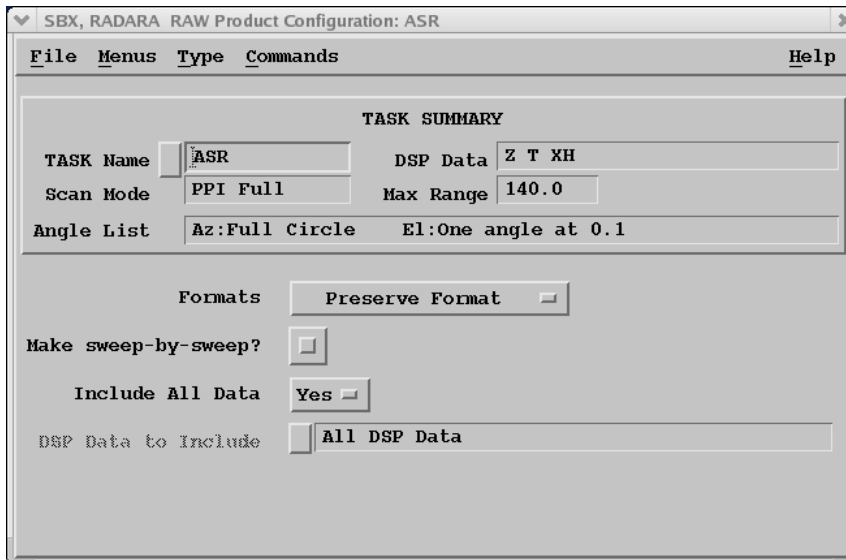

The screenshot shows a window titled "SBX, RADARA RAW Product Configuration: ASR". It has a menu bar with "File", "Menus", "Type", "Commands", and "Help". The main area is titled "TASK SUMMARY" and contains several configuration fields:

- TASK Name: ASR
- DSP Data: Z T XH
- Scan Mode: PPI Full
- Max Range: 140.0
- Angle List: Az:Full Circle El:One angle at 0.1
- Formats: Preserve Format (checkbox)
- Make sweep-by-sweep? (checkbox)
- Include All Data: Yes (checkbox)
- DSP Data to Include: All DSP Data

### RAW Product for WX\_SURV TASK

The screenshot shows a configuration window titled "SBX, RADARA RAW Product Configuration: WX\_SURV". It features a menu bar with "File", "Menus", "Type", "Commands", and "Help". The main area is divided into a "TASK SUMMARY" section and a configuration section. The "TASK SUMMARY" section contains the following fields: "TASK Name" (WX\_SURV), "Scan Mode" (PPI Full), "Angle List" (Az:Full Circle, El:One angle at 1.5), "DSP Data" (Z T V XH), and "Max Range" (599.6). The configuration section includes a "Formats" dropdown set to "Preserve Format", a "Make sweep-by-sweep?" checkbox (unchecked), an "Include All Data" dropdown set to "Yes", and a "DSP Data to Include" dropdown set to "All DSP Data".

### RAW Product for WX\_PPI\_VOL

The screenshot shows a configuration window titled "SBX, RADARA RAW Product Configuration: WX\_PPI\_VOL". It features a menu bar with "File", "Menus", "Type", "Commands", and "Help". The main area is divided into a "TASK SUMMARY" section and a configuration section. The "TASK SUMMARY" section contains the following fields: "TASK Name" (WX\_PPI\_VOL), "Scan Mode" (PPI Full), "Angle List" (Az:Full Circle, El:14 angles from 0.5 to 20.0), "DSP Data" (Z T V W XH), and "Max Range" (150.0). The configuration section includes a "Formats" dropdown set to "Preserve Format", a "Make sweep-by-sweep?" checkbox (unchecked), an "Include All Data" dropdown set to "Yes", and a "DSP Data to Include" dropdown set to "All DSP Data".

### 2.1.4 DEFAULT Product Output Menu

Used for all modes (DEFAULT, WX, ASR), This sends the RAW data products to the analysis node.

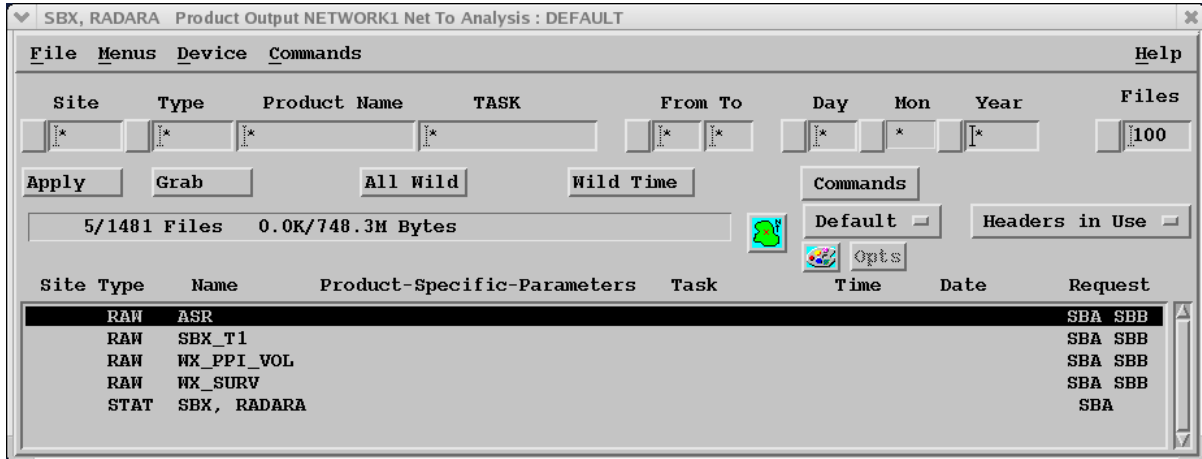

## 2.2 ASR Mode

This section shows the menus for the ASR scan mode, i.e., the Radar Status, TASK Scheduler and TASK Configuration Menus.

### 2.2.1 Radar Status Menu

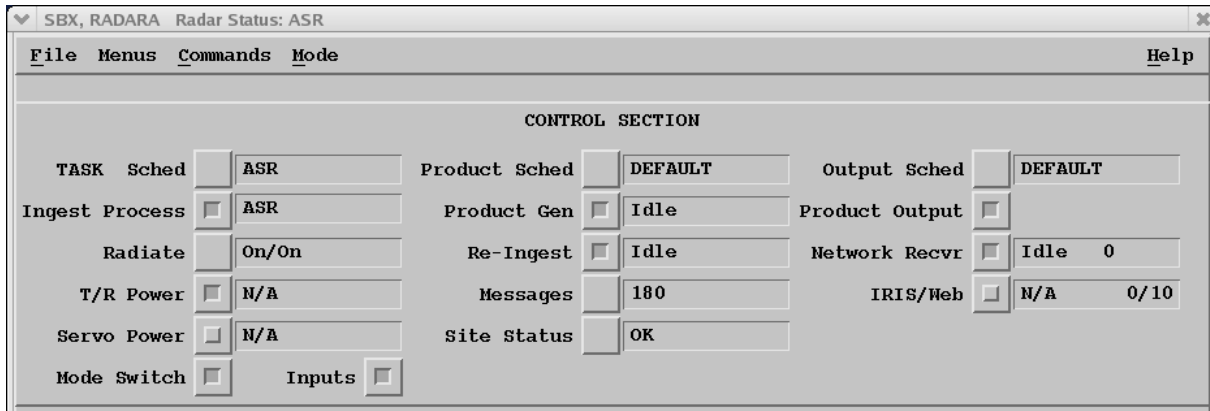

### 2.2.2 ASR TASK Configuration and Scheduling

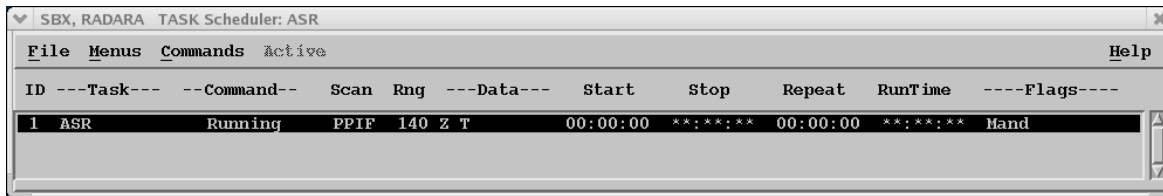

The ASR TASK is scheduled to run continuously.

The ASR scan TASK is a single sweep PPI at 5 RPM (30 degrees per second). Long pulse is used to optimize sensitivity.

SBX, RADARA TASK Configuration: ASR

File Menus Commands Help

Description Full Circle Aircraft Surv.

**ANTENNA /RADAR CONTROL**

Scan Mode PPI Full Resolution 1.000 Pulse Width 2.00

Azimuth Full Circle Gain Control Fixed

Elevation One angle at 0.1 Polarization Horiz

Scan Speed 30.00 deg/sec Ship Vel Correction

**PROCESSOR CONFIGURATION**

Data Z T Start Range 0.25 km Vel Unfold None

Z&T are SNR Bin Spacing 250.0 m High PRF 500 Hz

Samples 54 Range Avg/Smth 2 Low PRF 500 Hz

Filter Dop 5 Max Range 140.0 km Unamb Vel 6.8 m/s

Input Bins 560 Unamb Range 299.8 km Processing FFT

Output Bins 280 Phase Code Random

**DATA CORRECTIONS**

Clutter Map Beam Blockage Attenuation

Target Detect Unfold VC Remove Fallspeed in VC

**DATA QUALITY THRESHOLDING**

T LOG LOG SIG CSR SQI Defaults

Z LOG & CSR

V SQI & CSR

W SIG & SQI & LOG

ZDR LOG

3.5dB 5 dB 18 dB 0.58

Speckle Z V

## 2.3 WX Mode

This section shows the menus for the WX scan mode, i.e., the Radar Status, TASK Scheduler and TASK Configuration Menus.

### 2.3.1 Radar Status Menu

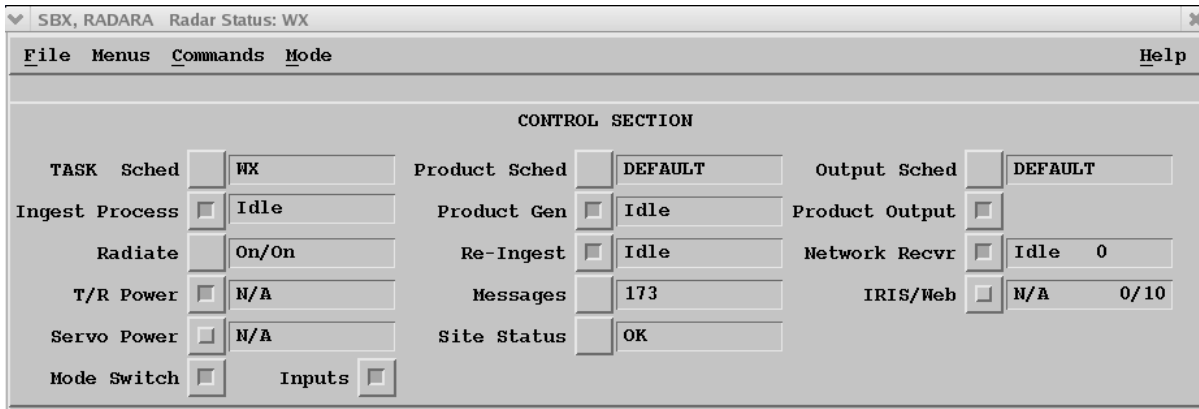

### 2.3.2 WX TASK Configuration and Scheduling

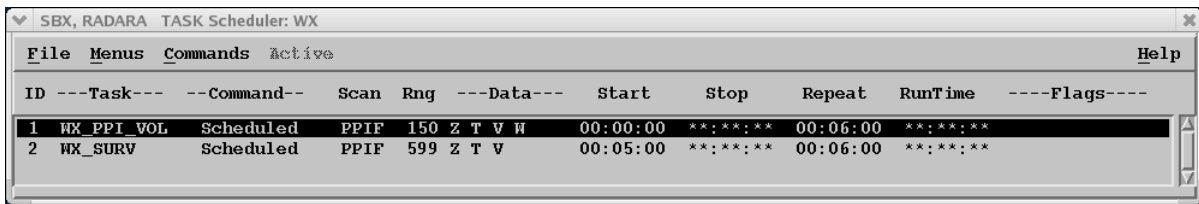

There are two WX TASKS:

- WX\_PPI\_VOL- a volume scan TASK to 150 km range. This is used for making most of the products. Multiple elevation angles are used.
- WX\_SURV- a long range surveillance TASK to 600 km range. This is used for making the 300 and 600 km long range PPI scans. One elevation angle is used.

WX\_SURV TASK Configuration

SBX, RADARA TASK Configuration: WX\_SURV

File Menus Commands Help

Description WX Single Elevation, Surveillance to 300 km

**ANTENNA /RADAR CONTROL**

Scan Mode **PPI Full** Resolution 1.000 Pulse Width 2.00  
 Azimuth Full Circle Gain Control Fixed  
 Elevation One angle at 1.5 Polarization Horiz  
 Scan Speed 9.00 deg/sec Ship Vel Correction

**PROCESSOR CONFIGURATION**

Data Z T V Start Range 0.25 km Vel Unfold None  
 Z&T are Reflectivity Bin Spacing 250.0 m High PRF 250 Hz  
 Samples 40 Range Avg/Smth 2 Low PRF 250 Hz  
 Filter Dop None Max Range 599.6 km Unamb Vel 3.4 m/s  
 Input Bins 2398 Unamb Range 599.6 km Processing FFT  
 Output Bins 1199 Phase Code Random

**DATA CORRECTIONS**

Clutter Map Beam Blockage Attenuation  
 Target Detect Unfold VC Remove Fallspeed in VC

**DATA QUALITY THRESHOLDING**

T LOG LOG SIG CSR SQI Defaults  
 Z LOG & CSR  
 V SQI & CSR  
 W SIG & SQI & LOG  
 ZDR LOG

LOG SIG CSR SQI Speckle  
 2.0dB 5 dB 18 dB 0.40 Z V

WX\_PPI\_VOL TASK Configuration

SBX, RADARA TASK Configuration: WX\_PPI\_VOL

File Menus Commands Help

Description

**ANTENNA /RADAR CONTROL**

Scan Mode  Resolution  Pulse Width

Azimuth  Gain Control

Elevation  Polarization

Scan Speed  Ship Vel Correction

**PROCESSOR CONFIGURATION**

Data  Start Range  Vel Unfold

Z&T are  Bin Spacing  High PRF

Samples  Range Avg/Smth  Low PRF

Filter Dop  Max Range  Unamb Vel

Input Bins  Unamb Range  Processing

Output Bins  Phase Code

**DATA CORRECTIONS**

Clutter Map  Beam Blockage  Attenuation

Target Detect  Unfold VC  Remove Fallspeed in VC

**DATA QUALITY THRESHOLDING**

T  LOG SIG CSR SQI Defaults

Z

V

W

ZDR

Speckle  Z  V

### 3. Analysis System Configuration

The analysis system performs the following functions (see diagram below):

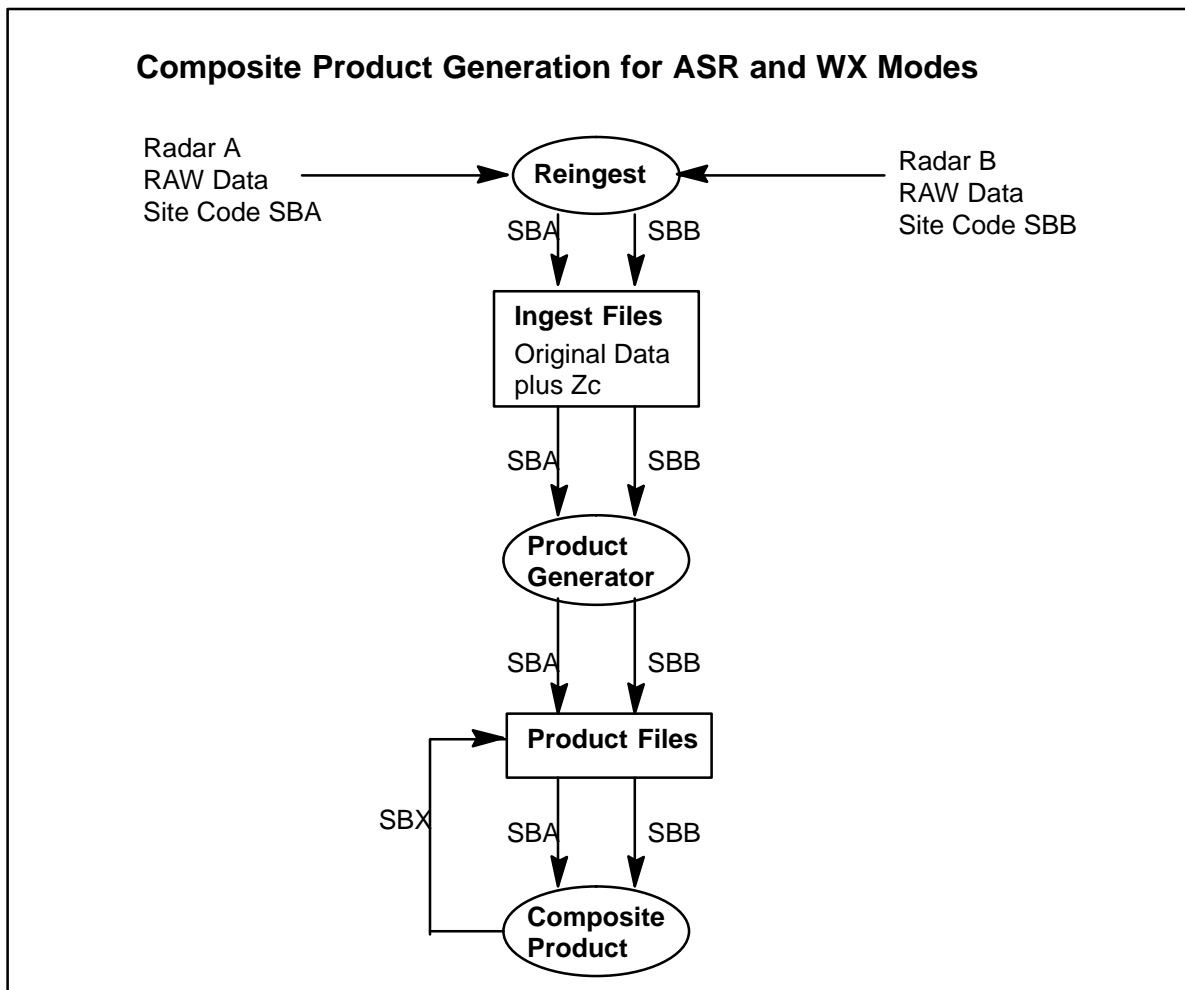

- Receives compressed RAW polar data from the two radar systems (site codes SBA and SBB).
- Reingests the data to make "Ingest Files". During the reingest process, a special "Target Filter" is applied to the RAW data. This filter passes point targets that are more than 10 dB stronger than the echo on either side in range and creates a new data variable called Zc—the filtered intensity. This is used in ASR mode. The original unfiltered intensity Z is left intact.
- Generates single-radar products for the two radars.
- Generates composite products by combining the individual products from the two radars. The composite site code is SBX. Composite products are of the same type as the two input products, e.g., if two input PPI's are composited, the output is a new PPI for site SBX.

In the case of the ASR mode, additional processing is performed on the composite PPI. This is shown schematically below:

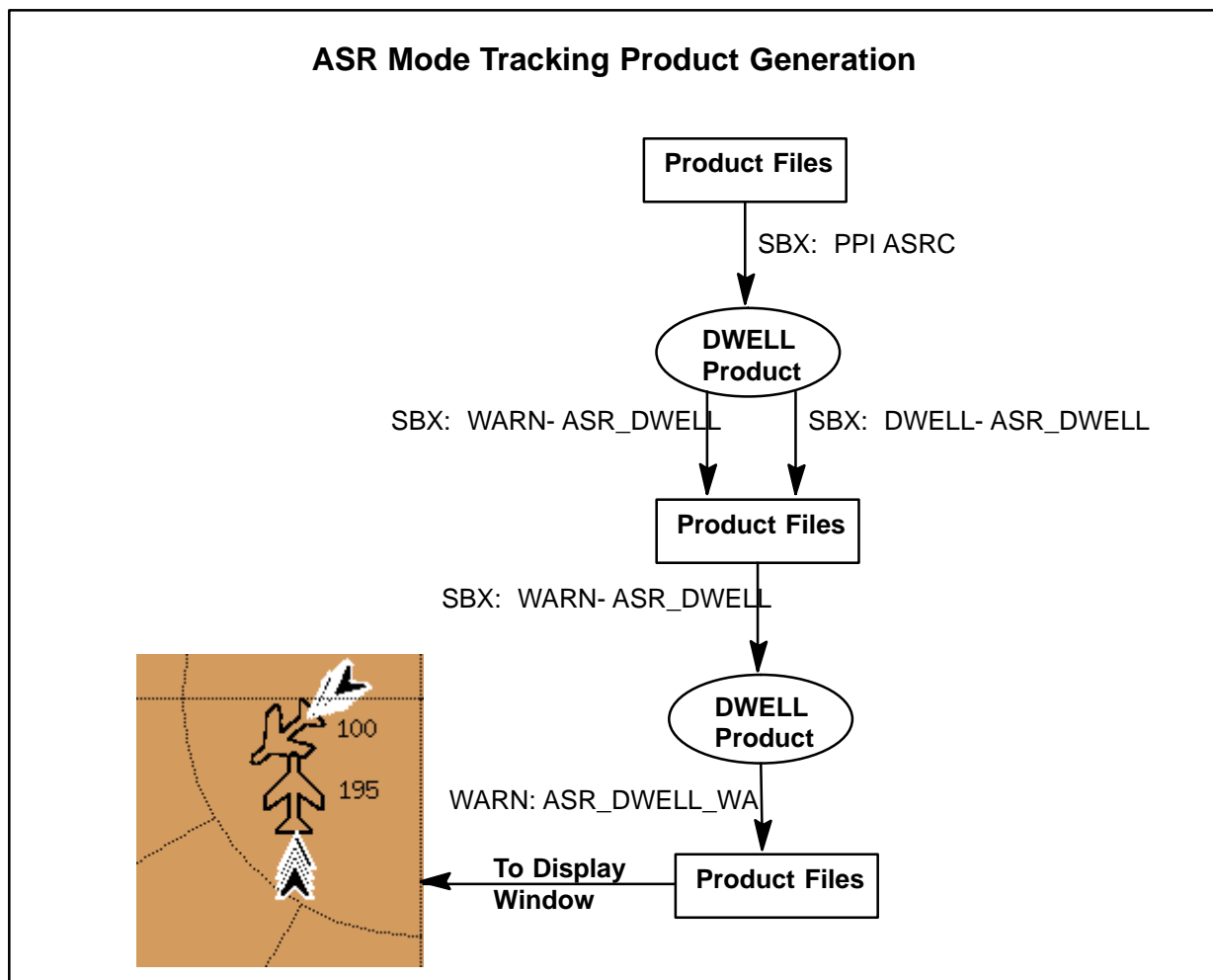

- The composite PPI of the target-filtered intensity (called ASRC) is run through a dwell product. This looks back in time 3 minutes (15 sweeps) and performs a correlation to detect targets that move with spatial coherence.
- The output of the DWEELL product is actually two products- a PPI product called ASR\_DWELL display that is the summation of the input products showing streaks of moving targets (imagine a camera shutter held open), and a WARN product called ASR\_DWELL that shows where moving targets have been detected. An alert is set if a target is within 20 km of the radar.
- The ASR\_DWELL WARN product is then run through the DWEELL product generator again so that the past 3-minute history of detections is added together into a WARN product called ASR\_DWELL\_WA. This is the detection display product used by observers.

### 3.0 "analysis" Setup Menu Listing

```
=====  
Radar Video Processor Setups, analysis  
=====  
System Type  
  System has a signal processor      : No  
Real Time Display  
  System transmits RTD              : No  
=====  
Radar Control Processor Setups, analysis  
=====  
Interface to RCP  
  System has an antenna             : No  
=====  
IRIS Input Device Setups, analysis  
=====  
Input Device Specifications  
  Number of input devices : 1  
Input Device #1  
  Menu alias               : From SIGMET  
  Pipe program name       :  
  Source directory        : /usr/iris_data/input/  
  Command line syntax     : Pipe  
  Notification scheme     : Polling  
=====  
IRIS INGEST Setups, analysis  
=====  
Data Source Selection  
  INGEST data source       : Simulated  
  Simulator virtual time offset : 0.0 minutes  
  Simulate a large-scale windfield : Yes  
  Nominal wind from the West   : 5.0 m/sec  
  Nominal wind from the South  : 1.0 m/sec  
  Vertical wind maximum speed  : 0.00 m/sec  
  Vertical wind cyclic height   : 5.0 km  
  Wind field deformation       : 0.0 m/sec/100km  
  Simulate a shearline        : Yes  
  Simulate particle fallspeeds : No  
  Simulation center location   : At the radar  
  Clutter density factor      : 100.0 %  
Signal Processing and Data Storage  
  Data truncation height      : 20.000 km  
  Type of angle syncing       : Dynamic  
  Manner of angle acquisition  : Binary TAGs  
  DSP parameter computations   : R2 algorithms  
  Extended header format      : Not Recorded  
Scanning Options  
  Reset the RCP on INGEST startup : No
```

Task Scheduling Control : Active Only  
RHI elevation speedup ratio : 10.00  
Permissible AZ error during scans : 0.30 degrees  
Permissible EL error during scans : 0.30 degrees  
AZ maximum speed at end positions : 0.50 deg/sec  
EL maximum speed at end positions : 0.50 deg/sec  
AZ speed tolerance : 3.00 deg/sec  
AZ minimum expected moving speed : 0.20 deg/sec  
EL minimum expected moving speed : 0.20 deg/sec  
AZ settling time between sweeps : 1.00 seconds  
EL settling time between sweeps : 1.00 seconds  
Direction of continuous scans : Clockwise  
Coasting time between tasks : 60 seconds max

DSP Noise Sampling  
Perform noise sampling : Periodically  
Time between noise samples : 60.0 minutes  
Azimuth during noise sample : Don't Care  
Elevation during noise sample : Minimum Angle  
Minimum noise elevation : 20 degrees  
Take sample whenever PW changes : No  
Retry bad noise samples : 1 time(s)  
Noise retry wait : 1.00 seconds

Transmitter Control  
Idle time to shut off transmitter : 300 seconds  
Warmup time for transmitter : 10 seconds  
Pulsewidth and PRF are set : at task start

Zc: Clutter Suppression via Clutter Map  
Excess power needed for valid dBZ : 10.0 dB  
Elevation tolerance for matchup : 1.00 degrees  
Non-zero velocity criterion : Check Velocity  
Clutter correction in ReINGEST : Disabled

Zc: Intervening Attenuation Correction  
Z attenuation constant : 0.000112 dB/km  
Z attenuation exponent : 0.62  
Maximum Z for correction : 50.0 dBZ  
Maximum cumulative correction : 6.0 dB  
Atten correction in ReINGEST : Disabled

Zc: Target Detection Correction  
Target detection in ReINGEST : Create Zc

Vc: VVP Unfolding of Velocity  
Maximum age of the "UNFOLD" VVP : 30.0 minutes  
Maximum separation to the VVP : 50.0 km  
Velocity unfolding in ReINGEST : Disabled

Vc: Velocity Fallspeed Correction  
Vt-Z Constant above melting level : 0.80 m/s  
Vt-Z Exponent above melting level : 0.060  
Vt-Z Constant below melting level : 2.70 m/s  
Vt-Z Exponent below melting level : 0.110  
Fallspeed correction in ReINGEST : Disabled

Melting Levels  
Melting Levels : Enabled

Melting level height for: January : 0.0 km  
February : 0.0 km  
March : 1.0 km  
April : 2.0 km  
May : 3.0 km  
June : 4.0 km  
July : 5.0 km  
August : 4.0 km  
September : 3.0 km  
October : 2.0 km  
November : 1.0 km  
December : 0.0 km

=====  
IRIS General Setups, analysis  
=====

Modes and Protocols

Timezone for data recording : UTC  
Operating system's time : Unaffected by IRIS  
Memory-mapped I/O : Available in OS  
External RCP mode change : Disabled  
External socket mode change : Disabled  
Status product mode change : Disabled  
Response to fatal errors : Restart Processes  
Maximum number of IRIS clients : 10 clients

Speech and Signaling

Signal network warnings < : 600 seconds old  
Speak/Beep text products : No  
Speak/Beep mode changes : No  
Speak/Beep fatal errors : No  
Speak/Beep BITE faults : Yes

File System Quotas

Total space for INGEST files : 500.0 megabytes  
Kept INGEST file space : 50% of total  
Total space for RAW products : 500.0 megabytes  
Kept RAW-Product file space : 50% of total  
Total space for Other-Products : 500.0 megabytes  
Kept Other-Product file space : 50% of total  
Maximum Products on Disk : 20000  
Maximum Products on Archive : 10000  
Number of LOG files to retain : 5

Run-Time Priorities

INGEST process priority : -8  
INGFIO process priority : -8  
INPUT process priority : 0  
PRODUCT process priority : 8  
REINGEST process priority : 8  
NETWORK process priority : 4  
OUTPUT process priority : 4  
ARCHIVE process priority : 4  
SERVER process priority : 0  
WATCHDOG process priority : 0

Window Alert Configuration

Multi-site fault rule : FAULT on one  
Alert Style : Disabled

List Of Radar Site Names and Site Codes

Site #0 (Unknown) code : XXX  
Check for Fault : No  
Site #1 name : SBX, DISPLAY  
Code : SBC  
Check for Fault : No  
Site #2 name : SBX, ANALYSIS  
Code : SBX  
Check for Fault : No  
Site #3 name : SBX, RADARA  
Code : SBA  
Check for Fault : No  
Site #4 name : SBX, RADARB  
Code : SBB  
Check for Fault : No  
Site #5 name :  
Site #6 name :  
Site #7 name :  
Site #8 name :  
Site #9 name :  
Site #10 name :  
Site #11 name :  
Site #12 name :  
Site #13 name :  
Site #14 name :  
Site #15 name :  
Site #16 name :  
Site #17 name :  
Site #18 name :  
Site #19 name :  
Site #20 name :  
Site #21 name :  
Site #22 name :  
Site #23 name :  
Site #24 name :  
Site #25 name :  
Site #26 name :  
Site #27 name :  
Site #28 name :  
Site #29 name :  
Site #30 name :

=====  
IRIS PRODUCT Setups, analysis  
=====

Product Generation

Products from partial INGEST scans : Yes  
Default Z/R relationship constant : 200.00  
Default Z/R relationship exponent : 1.60  
Product arrival wait time : 0.4 minutes  
Raingage data arrival wait time : 6.0 minutes

Signal if busy more than : 0.0 minutes  
Alternating polarization features : Disabled  
Read cache size : 0.0 megabytes  
Zero reference height : 0 meters

Reflectivity Profile and Wind  
Use Gradient in CAPPI & XSECT : Yes  
Gradient Above Melting : 7.0 dB/km  
Gradient Below Melting : 1.0 dB/km  
Melting Layer Thickness : 1.00 km  
Melting Layer Intensity : 7.0 dB  
Default Wind : Disabled

Status Products  
STATUS product generation : Enabled  
Time between status products : 1.0 minutes  
Make product for each task : Yes  
STATUS Prod maximum file count : 10 files  
STATUS product receive timeout : Enabled  
Timeout after : 2.0 minutes

Product Transmission and Display  
WARN max time difference : 2.0 minutes  
TRACK max time difference : 0.50 hours  
FCAST max time difference : 15.0 minutes  
Default max time difference : 0.0 minutes  
Maximum files queued for send : 5 files  
Centroid value signal : Average  
Label bottom of SLINE display : Enabled  
Label bottom of TDWR display : Enabled  
Label bottom of TRACK display : Enabled  
Label bottom of WARN display : Enabled

Product Scheduling  
BEAM Product Priority : 20  
CAPPI Product Priority : 20  
CATCH Product Priority : 0  
COMP Product Priority : 20  
DWELL Product Priority : 0  
FCAST Product Priority : 20  
HMAX Product Priority : 50  
MAX Product Priority : 20  
NDOP Product Priority : 20  
PPI Product Priority : 20  
RAIN1 Product Priority : 20  
RAINN Product Priority : 20  
RAW Product Priority : 20  
RHI Product Priority : 20  
RTI Product Priority : 0  
SHEAR Product Priority : 20  
SLINE Product Priority : 20  
SRI Product Priority : 0  
TOPS Product Priority : 20  
TRACK Product Priority : 20  
VIL Product Priority : 20  
VVP Product Priority : 20  
WARN Product Priority : 40

WIND Product Priority : 20  
XSECT Product Priority : 30

Warning Region #1  
Name : 10km  
Center East of the radar : 0.000 km  
Center North of the radar : 0.000 km  
Width East-West : 20.000 km  
Height North-South : 20.000 km  
Orientation : 0.00 degrees

Warning Region #2  
Name : 20km  
Center East of the radar : 0.000 km  
Center North of the radar : 0.000 km  
Width East-West : 40.000 km  
Height North-South : 40.000 km  
Orientation : 0.00 degrees

Warning Region #3  
Name : 30km  
Center East of the radar : 0.000 km  
Center North of the radar : 0.000 km  
Width East-West : 60.000 km  
Height North-South : 60.000 km  
Orientation : 0.00 degrees

Warning Region #4  
Name : 40km  
Center East of the radar : 0.000 km  
Center North of the radar : 0.000 km  
Width East-West : 80.000 km  
Height North-South : 80.000 km  
Orientation : 0.00 degrees

Warning Region #5  
Name : 50km  
Center East of the radar : 0.000 km  
Center North of the radar : 0.000 km  
Width East-West : 100.000 km  
Height North-South : 100.000 km  
Orientation : 0.00 degrees

Warning Region #6  
Name :

Warning Region #7  
Name :

Warning Region #8  
Name :

Warning Region #9  
Name :

Warning Region #10  
Name :

Warning Region #11  
Name :

```
Warning Region #12
  Name                               :
Warning Region #13
  Name                               :
Warning Region #14
  Name                               :
Warning Region #15
  Name                               :
Warning Region #16
  Name                               :
Warning Region #17
  Name                               :
Warning Region #18
  Name                               :
Warning Region #19
  Name                               :
Warning Region #20
  Name                               :
Warning Region #21
  Name                               :
Warning Region #22
  Name                               :
Warning Region #23
  Name                               :
Warning Region #24
  Name                               :
Warning Region #25
  Name                               :
Warning Region #26
  Name                               :
Warning Region #27
  Name                               :
Warning Region #28
  Name                               :
Warning Region #29
  Name                               :
Warning Region #30
  Name                               :
Warning Region #31
  Name                               :
Warning Region #32
  Name                               :

=====
License and Site Setups, analysis
=====
```

License and Site Information

00000001-060101-KJTJJPJ-01-XWWR4Y (IRIS Features)  
000081FF-060101-KJTJJPJ-03-WCAHKY (IRIS Products)

Analysis

SBX, ANALYSIS

SBX, ANALYSIS

\*\*\*\*\*

=====  
IRIS Output Device Setups, analysis  
=====

Output Device Specifications

Number of output devices : 4

Output Device #1

Device type : Window  
Unit number : 1  
Menu alias : ANIMATION  
Min time between output : 0 sec  
Device movie length : 300 frames  
Initial width of image : 720 pixels  
Initial height of image : 720 pixels  
Initial horizontal offset : 10 pixels  
Initial vertical offset : 10 pixels  
Slide Show : Disable on startup  
Display Name : :0.0

Output Device #2

Device type : Network  
Unit number : 1  
Menu alias : To Radar A  
Min time between output : 0 sec  
File format : IRIS (Def)  
Filename format : Default  
Compression scheme : None  
Notification scheme : TCPIP  
Target directory : /usr/iris\_data/product/  
Copy scheme : RCP  
User name : operator  
Notification port number : 30725  
Recipient host name : rcp-a

Output Device #3

Device type : Network  
Unit number : 2  
Menu alias : To Radar B  
Min time between output : 0 sec  
File format : IRIS (Def)  
Filename format : Default  
Compression scheme : None  
Notification scheme : TCPIP  
Target directory : /usr/iris\_data/product/  
Copy scheme : RCP  
User name : operator

```
Notification port number : 30725
Recipient host name      : rcp-b

Output Device #4
Device type              : Network
Unit number             : 3
Menu alias               : To Display
Min time between output : 0 sec
File format              : IRIS (Def)
Filename format         : Default
Compression scheme      : None
Notification scheme     : TCPIP
Target directory        : /usr/iris_data/product/
Copy scheme              : RCP
User name                : operator
Notification port number : 30725
Recipient host name     : display
```

```
=====
IRIS Web Setups, analysis
=====
```

```
IRIS Web Specifications
```

```
Max Simultaneous Clients : 3
Number of Web Users      : 4
Require Login            : No

Web User #1
User Name                : doug
Password                 : *****

Web User #2
User Name                : rich
Password                 : *****

Web User #3
User Name                : operator
Password                 : *****

Web User #4
User Name                : richard
Password                 : *****
```

### 3.1 DEFAULT Radar Status Menu

The Radar Status Menu for ASR and WX modes is identical except that the “Product Sched” is set to “ASR” or “WX”.

**IMPORTANT:** The Radar Status Menu mode (**FILE**→**Open**→ **ASR or WX**) controls the operating mode of the two radar systems.

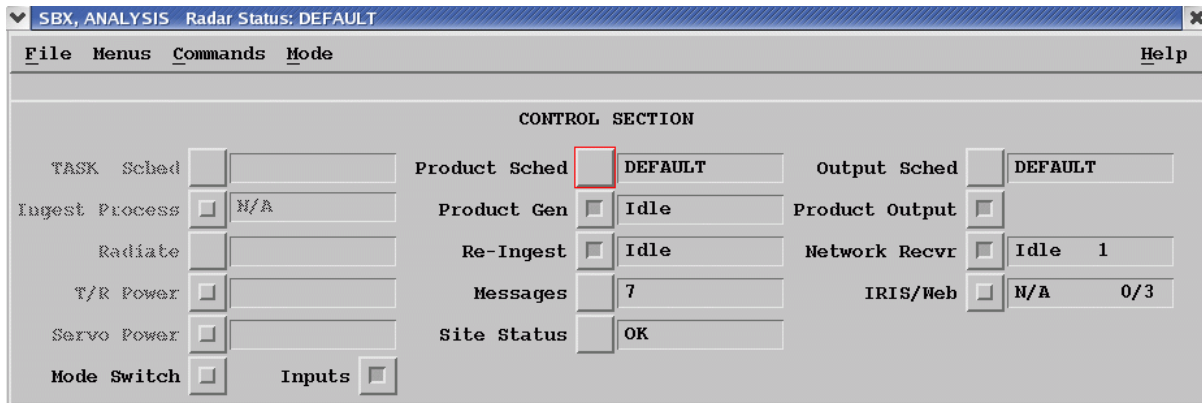

### 3.2 DEFAULT Mode Product Outputs

The output devices for the analysis system are:

- WINDOW 1                      ANIMATION
- NETWORK 1                    To Radar A
- NETWORK 2                    To Radar B
- NETWORK 3                    To Display

The automatic output assignments for each device are shown below. Note that these Product Output Menu displays were done by selecting the “Headers in use” option on the top left of the Product Output Menu filter section (just above the “Request” column).

#### WINDOW 1                      ANIMATION

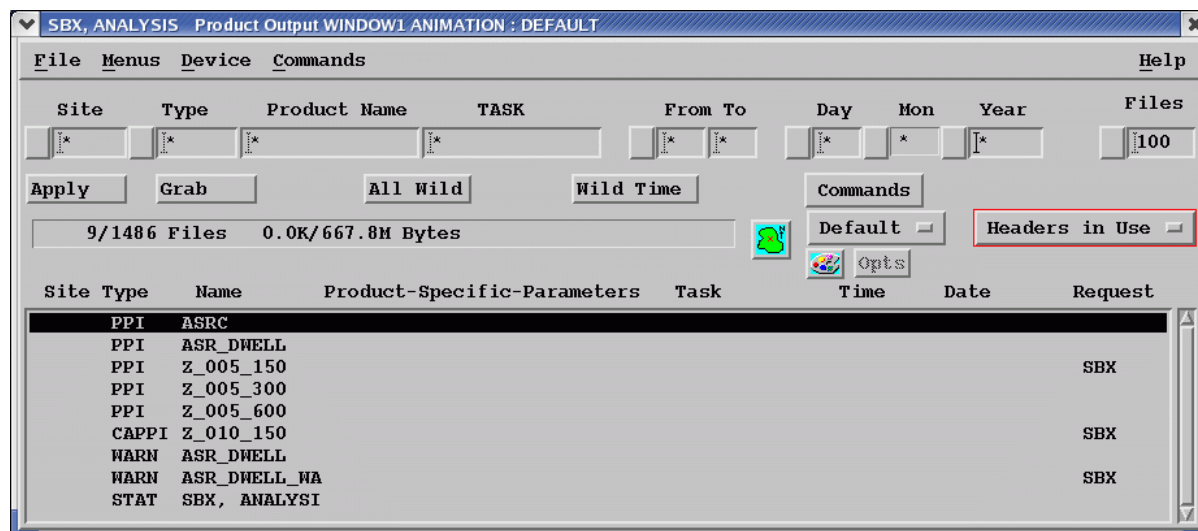

#### NETWORK 1                    To Radar A

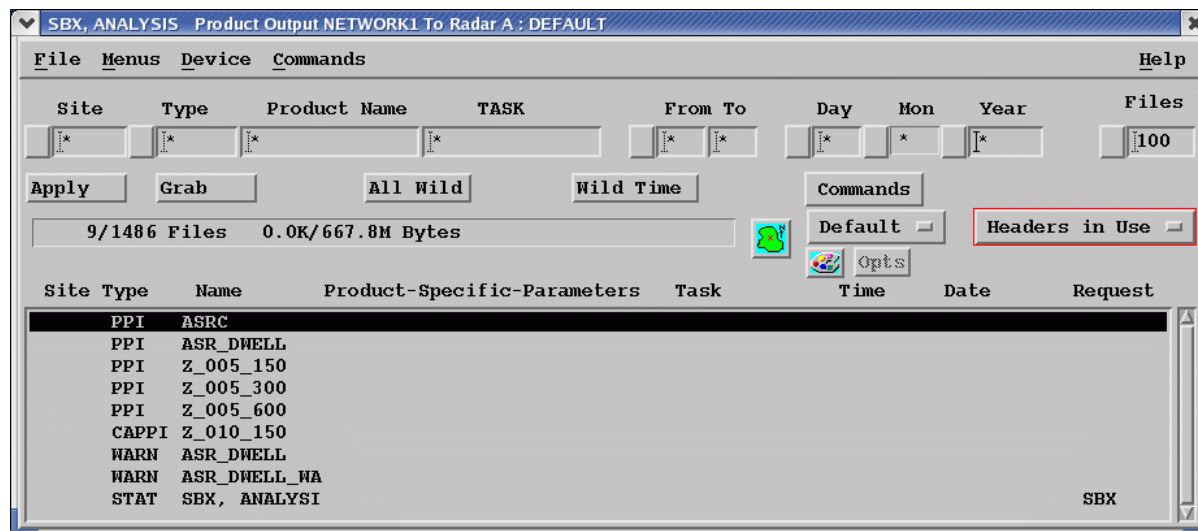

NETWORK 2      To Radar B

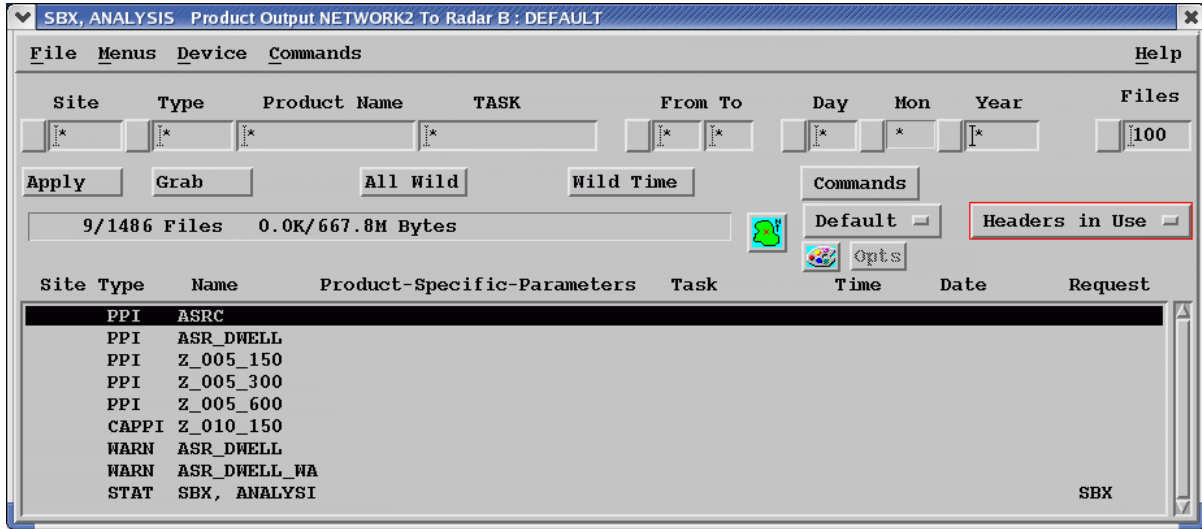

NETWORK 3      To Display

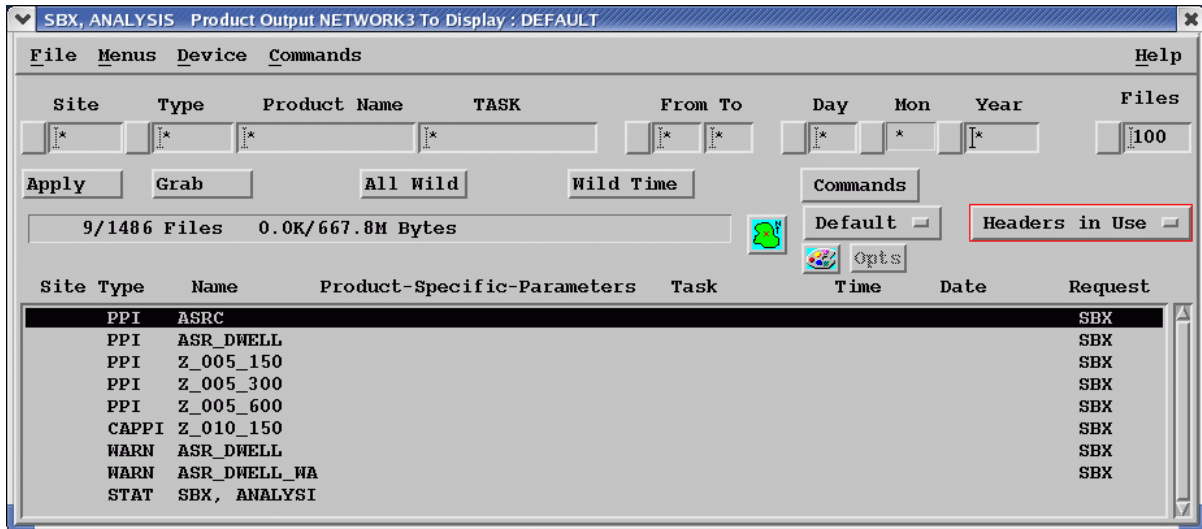

### 3.3 ASR Mode Products

For a description of the ASR mode products, see the overview at the beginning of section 3. In addition to the target detection product (ASR\_DWELL\_WA) an intensity PPI product called ASR is also produced.

#### 3.3.1 ASR Mode Product Scheduler Menu

The screenshot shows a window titled 'SBX, ANALYSIS Product Scheduler: ASR'. It features a menu bar with 'File', 'Menus', 'Commands', and 'Help'. Below the menu bar, there are several controls: 'Display' (with a red box around it), '30/32 Products', 'Add for' (with a red box around it), and 'Site Group' (set to 2). The main area contains a table with the following columns: Site, Product, Data, TASK, Next-Data-Time, Skip, Rqst, Status, and Runs. The table lists various products, including ASR and ASR\_DWELL\_WA.

Site	Product	Data	TASK	Next-Data-Time	Skip	Rqst	Status	Runs	
	BASE	--Products--							
	BEAM	--Products--							
	CAPPI	--Products--							
	COMP	--Products--							
---	COMP	ASR	PPI	ASR	21:05 26 MAR 2005	00:00	All	Wait	0
---	COMP	ASRC	PPI	ASRC	21:05 26 MAR 2005	00:00	All	Wait	0
	DWELL	--Products--							
SBX	DWELL	ASR_DWELL	PPI	ASRC	21:05 26 MAR 2005	00:00	All	Wait	0
SBX	DWELL	ASR_DWELL_WA	WARN	ASR_DWELL	21:05 26 MAR 2005	00:00	All	Wait	0
	FCAST	--Products--							
	HMAX	--Products--							
	MAX	--Products--							
	NDOP	--Products--							
	PPI	--Products--							
SBA	PPI	ASR	dBZ	ASR	21:05 26 MAR 2005	00:00	All	Wait	0
SBA	PPI	ASRC	dBZc	ASR	21:05 26 MAR 2005	00:00	All	Wait	0
	RAIN1	--Products--							
	RAINN	--Products--							

#### 3.3.2 ASR Mode Product Configuration Menus

The screenshot shows a window titled 'SBX, ANALYSIS COMP Product Configuration: ASR'. It features a menu bar with 'File', 'Menus', 'Type', 'Commands', and 'Help'. The window is divided into three sections: 'Input Product and Sites', 'Composite Geometry', and 'Product Generation Parameters'. In the 'Input Product and Sites' section, 'Type' is set to PPI (with a red box around it), 'Product Name' is ASR, and 'Radar Sites' are SBB and SBA. In the 'Composite Geometry' section, 'Output Site ID' is SBX, 'Map Projection' is Azimuthal Eqdist, 'Projection Name' is BRO, 'Max Range' is 150.0, and 'Resolution' is 400 x 400. In the 'Product Generation Parameters' section, 'Max Time Span (min)' is 1.0, 'Combine by' is Maximum, and 'XY Smoother (km)' is 0.0.

SBX, ANALYSIS COMP Product Configuration: ASRC

File Menus Type Commands Help

Input Product and Sites

Type	Product Name	Radar Sites
PPI	ASRC	SBB SBA

Composite Geometry

Output Site ID: SBX

Map Projection: Azimuthal Eqdist Projection Name: BRO

Max Range: 150.0 Resolution: 400 x 400

Product Generation Parameters

Max Time Span (min): 1.0 Combine by: Maximum

XY Smoother (km): 0.0

SBX, ANALYSIS DWELL Product Configuration: ASR\_DWELL

File Menus Type Commands Help

**TASK SUMMARY**

TASK Name  DSP Data   
Scan Mode  Max Range   
Angle List

Input Product  Type  Product Name  Time  Data Type

**INPUT PRODUCT FILTERS** **DISPLAY PARAMETERS**

Intensity   Min   Max  
Contrastor   Thresh  %Coverage  
Sep PPIs   
Dwell Output  Target Detection   
Display Units   
Color Scale   
Levels   
1st Level/Step    
Resolution

**TARGET DETECTION**

Warning Symbol  Speed   Min  Max  Step  
Correlation Thresh  Heading CW  Min  Max  Step  
Add Wind  Use VWP  Target Size

**PROTECTED AREAS FOR WARNING ALERT**

TDWR Style  Say/Beep Warning  Make Diagnostic

ASR\_DWELL uses is based on ASRC which is target filtered (Zc).

**SBX, ANALYSIS DWELL Product Configuration: ASR\_DWELL\_WA**

File Menus Type Commands Help

**TASK SUMMARY**

TASK Name: ASR DSP Data: Z Zc T XH  
Scan Mode: PPI Full Max Range: 140.0  
Angle List: Az:Full Circle El:One angle at 4.0

Input Product	Type	Product Name	Time	Data Type
WARN		ASR_DWELL	3.0	----

**INPUT PRODUCT FILTERS**

Intensity:  None  None  
Contrastor:  None  None  
Sep PPIs:   
Dwell Output:  Data  Target Detection

**DISPLAY PARAMETERS**

Display Units: -----  
Color Scale: Default  
Levels: 16  
1st Level/Step: N/A N/A  
Resolution: 800 x 800

**SBX, ANALYSIS PPI Product Configuration: ASR**

File Menus Type Commands Help

**TASK SUMMARY**

TASK Name: ASR DSP Data: Z Zc T XH  
Scan Mode: PPI Full Max Range: 140.0  
Angle List: Az:Full Circle El:One angle at 4.0

Map Projection: Azimuthal Eqdist Projection Name: BRO

**PRODUCT PARAMETERS**

Data:Display: dBZ  
Max Range: 150.0  
EL Angle: \*  
Clip Range: 0.0 km  
Clip Height: 0.0 km  
ZR relation: 200 \*\* 1.60  
XY Smoother: 0.0

**DISPLAY PARAMETERS**

Display Units: -32 to 96 dBZ  
Color Scale: Default  
Levels: 16  
1st Level/Step: N/A N/A  
Resolution: 400 x 400

Note: PPI ASR Based on the data type Z- normal intensity with NO target filter.

The screenshot shows a software window titled "SBX, ANALYSIS PPI Product Configuration: ASRC". The window has a menu bar with "File", "Menus", "Type", "Commands", and "Help". The main content is organized into several sections:

- TASK SUMMARY**:
  - TASK Name: ASR
  - DSP Data: Z Zc T XH
  - Scan Mode: PPI Full
  - Max Range: 140.0
  - Angle List: Az:Full Circle El:One angle at 4.0 (highlighted with a red box)
- Map Projection: Azimuthal Eqdist (dropdown)
- Projection Name: BRO
- PRODUCT PARAMETERS**:
  - Data:Display: dBZc
  - Max Range: 150.0
  - EL Angle: \*
  - Clip Range: 0.0 km
  - Clip Height: 0.0 km
  - ZR relation: 200 \*\* 1.60
  - XY Smoother: 0.0
- DISPLAY PARAMETERS**:
  - Display Units: -32 to 96 dBZ
  - Color Scale: Default (dropdown)
  - Levels: 16 (dropdown)
  - 1st Level/Step: N/A
  - Resolution: 400 x 400

Note: PPI ASRC Based on the data type Zc– intensity with target filter.

### 3.4 WX Mode Products

For a general description of the WX mode product generation and compositing, see the overview at the beginning of section 3.

#### 3.4.1 Wx Mode Product Scheduler Menu

Note that the “Site” column has both SBA and SBB sites for each product. Only the SBA sites are displayed in the example below. To verify that both sites are defined, select “Display” to “All Sites”, or highlight a line in the schedule and right click the mouse in the site column to display and configure the sites for which the product will be produced.

Site	Product	Data	TASK	Next-Data-Time	Skip	Rqst	Status	Runs	
	BASE	--Products--							
	BEAM	--Products--							
	CAPPI	--Products--							
SBA	CAPPI	Z_010_150	dBZ	WX_PPI_VOL	21:22 26 MAR 2005	00:00	All	Wait	0
SBA	CAPPI	Z_020_150	dBZ	WX_PPI_VOL	21:22 26 MAR 2005	00:00	All	Wait	0
SBA	CAPPI	Z_030_150	dBZ	WX_PPI_VOL	21:22 26 MAR 2005	00:00	All	Wait	0
SBA	CAPPI	Z_050_150	dBZ	WX_PPI_VOL	21:22 26 MAR 2005	00:00	All	Wait	0
SBA	CAPPI	Z_100_150	dBZ	WX_PPI_VOL	21:22 26 MAR 2005	00:00	All	Wait	0
	COMP	--Products--							
---	COMP	01_20_150	VIL	01_20_150	21:22 26 MAR 2005	00:00	All	Wait	0
---	COMP	20DBZ_150	TOPS	20DBZ_150	21:22 26 MAR 2005	00:00	All	Wait	0
---	COMP	VIL	WARN	VIL	21:22 26 MAR 2005	00:00	All	Wait	0
---	COMP	Z_005_150	PPI	Z_005_150	21:22 26 MAR 2005	00:00	All	Wait	0
---	COMP	Z_005_300	PPI	Z_005_300	21:22 26 MAR 2005	00:00	All	Wait	0
---	COMP	Z_010_150	CAPPI	Z_010_150	21:22 26 MAR 2005	00:00	All	Wait	0
---	COMP	Z_020_150	CAPPI	Z_020_150	21:22 26 MAR 2005	00:00	All	Wait	0
---	COMP	Z_030_150	CAPPI	Z_030_150	21:22 26 MAR 2005	00:00	All	Wait	0
---	COMP	Z_050_150	CAPPI	Z_050_150	21:22 26 MAR 2005	00:00	All	Wait	0
---	COMP	Z_100_150	CAPPI	Z_100_150	21:22 26 MAR 2005	00:00	All	Wait	0
	DWELL	--Products--							
	FCAST	--Products--							
	HMAX	--Products--							
	MAX	--Products--							
	NDOP	--Products--							
	PPI	--Products--							
SBA	PPI	V_005_150	V	WX_PPI_VOL	21:22 26 MAR 2005	00:00	All	Wait	0
SBA	PPI	W_005_150	W	WX_PPI_VOL	21:22 26 MAR 2005	00:00	All	Wait	0
SBA	PPI	Z_005_150	dBZ	WX_PPI_VOL	21:22 26 MAR 2005	00:00	All	Wait	0
SBA	PPI	Z_005_300	dBZ	WX_SURV	21:22 26 MAR 2005	00:00	All	Wait	0
SBA	PPI	Z_005_600	dBZ	WX_SURV	21:22 26 MAR 2005	00:00	All	Wait	0
	RAIN1	--Products--							
	RAINN	--Products--							
	RAW	--Products--							
	RHI	--Products--							
	RTI	--Products--							
	SRI	--Products--							
	TOPS	--Products--							
SBA	TOPS	20DBZ_150	Height	WX_PPI_VOL	21:22 26 MAR 2005	00:00	All	Wait	0
	TRACK	--Products--							
	VIL	--Products--							
SBA	VIL	01_20_150	VIL	WX_PPI_VOL	21:22 26 MAR 2005	00:00	All	Wait	0
	VVP	--Products--							
	WARN	--Products--							
SBA	WARN	VIL	VIL	01_20_150	21:22 26 MAR 2005	00:00	All	Wait	0
	WIND	--Products--							
	XSECT	--Products--							

### 3.4.2 Wx Mode Product Configurations

All CAPPI products are configured identically except for the CAPPI height. The naming convention for a CAPPI product is parameter\_height\_range, e.g., Z\_010\_150 corresponds to radar reflectivity at 1.0 km height and 150 km range.

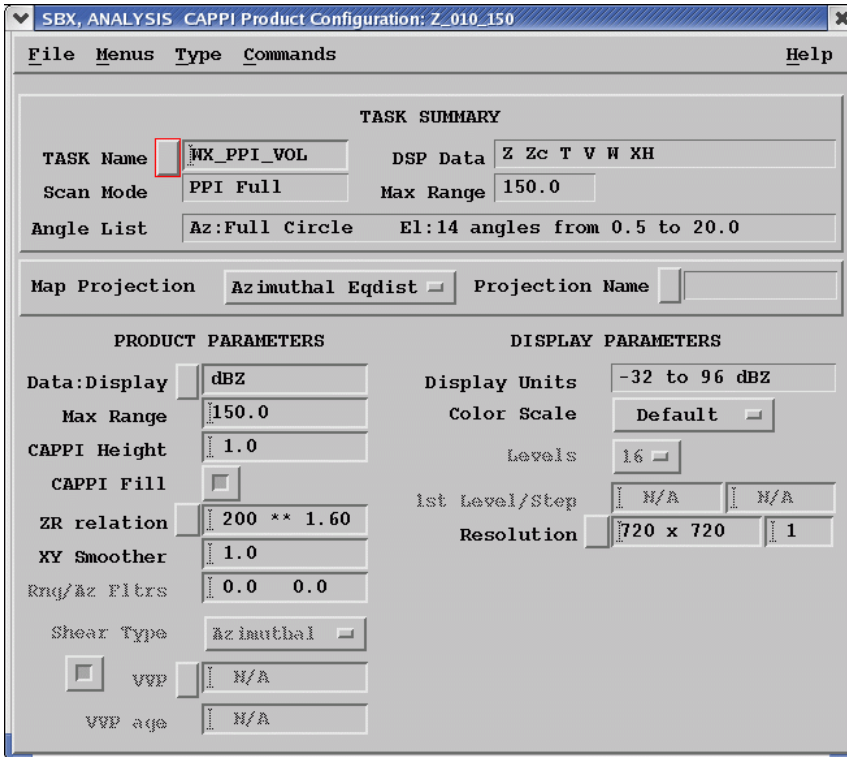

SBX, ANALYSIS COMP Product Configuration: 01\_20\_150

File Menus Type Commands Help

Input Product and Sites

Type	Product Name	Radar Sites
<input type="checkbox"/> VIL	01_20_150	<input type="checkbox"/> SBB SBA

Composite Geometry

Output Site ID: SBX

Map Projection: Azimuthal Eqdist Projection Name: BRO

Max Range: 150.0 Resolution: 400 x 400

Product Generation Parameters

Max Time Span (min): 10.0 Combine by: Priority

XY Smoother (km): 1.0

SBX, ANALYSIS COMP Product Configuration: 20DBZ\_150

File Menus Type Commands Help

Input Product and Sites

Type	Product Name	Radar Sites
<input type="checkbox"/> TOPS	20DBZ_150	<input type="checkbox"/> SBB SBA

Composite Geometry

Output Site ID: SBX

Map Projection: Azimuthal Eqdist Projection Name: BRO

Max Range: 150.0 Resolution: 400 x 400

Product Generation Parameters

Max Time Span (min): 10.0 Combine by: Priority

XY Smoother (km): 1.0

SBX, ANALYSIS COMP Product Configuration: VIL

File Menus Type Commands Help

**Input Product and Sites**

Type	Product Name	Radar Sites
<input type="checkbox"/> WARN	VIL	<input type="checkbox"/> SBB SBA

**Composite Geometry**

Output Site ID: SBX

Map Projection: Azimuthal Eqdist  
Projection Name: BRO

Max Range: 150.0  
Resolution: 400 x 400

**Product Generation Parameters**

Max Time Span (min): 10.0  
Combine by: OR Max

Centroid Dist (km): 1.0

SBX, ANALYSIS PPI Product Configuration: V\_005\_150

File Menus Type Commands Help

**TASK SUMMARY**

TASK Name: WX\_PPI\_VOL  
Scan Mode: PPI Full  
Angle List: Az:Full Circle

DSP Data: Z Zc T V W XH  
Max Range: 150.0  
El: 14 angles from 0.5 to 20.0

Map Projection: Azimuthal Eqdist  
Projection Name:

<b>PRODUCT PARAMETERS</b>	<b>DISPLAY PARAMETERS</b>
Data:Display: V	Display Units: +- Vu m/s
Max Range: 150.0	Color Scale: Default
EL Angle: 0.5	Levels: 15
Clip Range: 0.0 km	1st Level/Step: N/A
Clip Height: 0.0 km	Resolution: 720 x 720
ZR relation: 200 ** 1.60	
XY Smoother: 1.0	

The screenshot shows a software window titled "SBX, ANALYSIS COMP Product Configuration: Z\_005\_300". It features a menu bar with "File", "Menus", "Type", "Commands", and "Help". The window is divided into three main sections:

- Input Product and Sites:** Contains a table with columns "Type", "Product Name", and "Radar Sites". The "Type" column has a dropdown menu with "PPI" selected. The "Product Name" field contains "Z\_005\_300". The "Radar Sites" field contains "SBB SBA".
- Composite Geometry:** Contains fields for "Output site ID" (SBX), "Map Projection" (Azimuthal Eqdist), "Projection Name" (BRO), "Max Range" (150.0), and "Resolution" (400 x 400).
- Product Generation Parameters:** Contains fields for "Max Time Span (min)" (10.0), "XY Smoother (km)" (1.0), and "Combine by" (Priority).

The screenshot shows a software window titled "SBX, ANALYSIS COMP Product Configuration: Z\_010\_150". It features a menu bar with "File", "Menus", "Type", "Commands", and "Help". The window is divided into three main sections:

- Input Product and Sites:** Contains a table with columns "Type", "Product Name", and "Radar Sites". The "Type" column has a dropdown menu with "CAPPI" selected. The "Product Name" field contains "Z\_010\_150". The "Radar Sites" field contains "SBB SBA".
- Composite Geometry:** Contains fields for "Output site ID" (SBX), "Map Projection" (Azimuthal Eqdist), "Projection Name" (BRO), "Max Range" (150.0), and "Resolution" (400 x 400).
- Product Generation Parameters:** Contains fields for "Max Time Span (min)" (10.0), "XY Smoother (km)" (1.0), and "Combine by" (Priority).

Note that all CAPPI composites for the different heights have the identical form. The composite configurations for these are not shown here.

SBX, ANALYSIS PPI Product Configuration: V\_005\_150

File Menus Type Commands Help

**TASK SUMMARY**

TASK Name	<input type="text" value="WX_PPI_VOL"/>	DSP Data	<input type="text" value="Z Zc T V W XH"/>
Scan Mode	<input type="text" value="PPI Full"/>	Max Range	<input type="text" value="150.0"/>
Angle List	<input type="text" value="Az:Full Circle El:14 angles from 0.5 to 20.0"/>		

Map Projection  Projection Name

PRODUCT PARAMETERS		DISPLAY PARAMETERS	
Data:Display	<input type="text" value="V"/>	Display Units	<input type="text" value="+- Vu m/s"/>
Max Range	<input type="text" value="150.0"/>	Color Scale	<input type="text" value="Default"/>
EL Angle	<input type="text" value="0.5"/>	Levels	<input type="text" value="15"/>
Clip Range	<input type="text" value="0.0 km"/>	1st Level/Step	<input type="text" value="N/A"/> <input type="text" value="N/A"/>
Clip Height	<input type="text" value="0.0 km"/>	Resolution	<input type="text" value="720 x 720"/> <input type="text" value="--"/>
ZR relation	<input type="text" value="200 ** 1.60"/>		
XY Smoother	<input type="text" value="1.0"/>		

SBX, ANALYSIS PPI Product Configuration: W\_005\_150

File Menus Type Commands Help

**TASK SUMMARY**

TASK Name	<input type="text" value="WX_PPI_VOL"/>	DSP Data	<input type="text" value="Z Zc T V W XH"/>
Scan Mode	<input type="text" value="PPI Full"/>	Max Range	<input type="text" value="150.0"/>
Angle List	<input type="text" value="Az:Full Circle El:14 angles from 0.5 to 20.0"/>		

Map Projection  Projection Name

PRODUCT PARAMETERS		DISPLAY PARAMETERS	
Data:Display	<input type="text" value="W"/>	Display Units	<input type="text" value="0 to Vu m/s"/>
Max Range	<input type="text" value="150.0"/>	Color Scale	<input type="text" value="Default"/>
EL Angle	<input type="text" value="0.5"/>	Levels	<input type="text" value="16"/>
Clip Range	<input type="text" value="0.0 km"/>	1st Level/Step	<input type="text" value="N/A"/> <input type="text" value="N/A"/>
Clip Height	<input type="text" value="0.0 km"/>	Resolution	<input type="text" value="720 x 720"/> <input type="text" value="--"/>
ZR relation	<input type="text" value="200 ** 1.60"/>		
XY Smoother	<input type="text" value="1.0"/>		

SBX, ANALYSIS PPI Product Configuration: Z\_005\_150

File Menus Type Commands Help

**TASK SUMMARY**

TASK Name	WX_PPI_VOL	DSP Data	Z Zc T V W XH
Scan Mode	PPI Full	Max Range	150.0
Angle List	Az:Full Circle El:14 angles from 0.5 to 20.0		

Map Projection  Azimuthal Eqdist  Projection Name

PRODUCT PARAMETERS		DISPLAY PARAMETERS	
Data:Display	dBZ	Display Units	-32 to 96 dBZ
Max Range	150.0	Color Scale	Default <input type="checkbox"/>
EL Angle	0.5	Levels	16 <input type="checkbox"/>
Clip Range	0.0 km	1st Level/Step	N/A N/A
Clip Height	0.0 km	Resolution	720 x 720 --
ZR relation	200 ** 1.60		
XY Smoother	1.0		

SBX, ANALYSIS PPI Product Configuration: Z\_005\_300

File Menus Type Commands Help

**TASK SUMMARY**

TASK Name	WX_SURV	DSP Data	Z Zc T V XH
Scan Mode	PPI Full	Max Range	599.6
Angle List	Az:Full Circle El:One angle at 1.5		

Map Projection  Azimuthal Eqdist  Projection Name

PRODUCT PARAMETERS		DISPLAY PARAMETERS	
Data:Display	dBZ	Display Units	-32 to 96 dBZ
Max Range	300.0	Color Scale	Default <input type="checkbox"/>
EL Angle	0.5	Levels	16 <input type="checkbox"/>
Clip Range	0.0 km	1st Level/Step	N/A N/A
Clip Height	0.0 km	Resolution	720 x 720 --
ZR relation	200 ** 1.60		
XY Smoother	1.0		

SBX, ANALYSIS PPI Product Configuration: Z\_005\_600

File Menus Type Commands Help

**TASK SUMMARY**

TASK Name	WX_SURV	DSP Data	Z Zc T V XH
Scan Mode	PPI Full	Max Range	599.6
Angle List	Az:Full Circle El:One angle at 1.5		

Map Projection  Azimuthal Eqdist  Projection Name

PRODUCT PARAMETERS		DISPLAY PARAMETERS	
Data:Display	dBZ	Display Units	-32 to 96 dBZ
Max Range	600.0	Color Scale	Default <input type="checkbox"/>
EL Angle	0.5	Levels	16 <input type="checkbox"/>
Clip Range	0.0 km	1st Level/Step	N/A N/A
Clip Height	0.0 km	Resolution	720 x 720 --
ZR relation	200 ** 1.60		
XY Smoother	1.0		

SBX, ANALYSIS TOPS Product Configuration: 20DBZ\_150

File Menus Type Commands Help

**TASK SUMMARY**

TASK Name	WX_PPI_VOL	DSP Data	Z Zc T V W XH
Scan Mode	PPI Full	Max Range	150.0
Angle List	Az:Full Circle El:14 angles from 0.5 to 20.0		

Map Projection  Azimuthal Eqdist  Projection Name

PRODUCT PARAMETERS		DISPLAY PARAMETERS	
Data:Display	dBZ:Height	Display Units	0 to 25.3 km
Max Range	149.9	Color Scale	Default <input type="checkbox"/>
dBZ Contour	20.0	Levels	16 <input type="checkbox"/>
XY Smoother	2.0	1st Level/Step	N/A N/A
		Resolution	720 x 720 --

SBX, ANALYSIS VIL Product Configuration: 01\_20\_150

File Menus Type Commands Help

**TASK SUMMARY**

TASK Name:  DSP Data:   
 Scan Mode:  Max Range:   
 Angle List:  El:14 angles from 0.5 to 20.0

Map Projection:  Projection Name:

**PRODUCT PARAMETERS** **DISPLAY PARAMETERS**

Data:Display:  Display Units:   
 Max Range:  Color Scale:   
 Layer Top:  Levels:   
 Layer Bottom:  1st Level/Step:    
 ZW relation:  Resolution:    
 XY Smoother:

SBX, ANALYSIS WARN Product Configuration: VIL

File Menus Type Commands Help

Warning Symbol:   
 Area in Sq Km:

Type	Product Name	Time	Threshold	
<input type="text" value="VIL"/>	<input type="text" value="01_20_150"/>	<input type="text" value="00:02:00"/>	<input type="text" value="2.00"/>	<input type="button" value="Apply"/> <input type="button" value="Clear"/>
1	VIL	01_20_150	00:02:00	> 2.00
2				
3				

**PROTECTED AREAS FOR WARNING ALERT**

40km  50km

TDWR Style:  Say/Beep Warning:  Make Diagnostic: